

2016



Big Block Modifieds
358 Modifieds
Sportsman Modifieds
Pro Stock
Super DIRTcar Series

General Rules and Specifications



7575 West Winds Blvd. Concord, NC 28027
704-795-7223
www.dirtcar.com

Primary DIRTcar Northeast Contacts

DIRTcar Northeast Director

Jeff Hachmann

jhachmann@dirtdcar.com

315-283-3367

DIRTcar Northeast Director of Series and Sanctioning

Mike Perrotte

mperrotte@dirtdcar.com

704-796-4566

DIRTcar Northeast Technical Director

nedirtcartech@dirtdcar.com

Gary Spaid, DIRTcar Points & Handicapping

aces2@frontiernet.net

585-734-5959

John Nelson, Series/Event Director

jnelson@dirtdcar.com

716-907-1905

Denis Moquin, Series/Event Director

dmoquin@dirtdcar.com

613-978-3475

Dave Farney, Series/Event Director

dfarney10@gmail.com

315-708-4422

Cory Reed, Series/Event Director

creed7171@gmail.com

315-374-1168

John Baumes, Series Marketing

jbaumes@dirtdcar.com 518-844-2678

World Racing Group Contacts:

Tracey McDaniel, Membership Coordinator

tmcdaniel@dirtdcar.com

704-795-7223

Heather Blackwood, Marketing Services

hblackwood@dirtdcar.com

704-795-7223

Aaron Fiedler – Manager, Public Relations

afiedler@dirtdcar.com

704-795-7223

SANCTIONED TRACKS

ALBANY-SARATOGA SPEEDWAY

Physical Address: 2671 US 9, Malta, NY 12020

Owners: Howard Commander

Promoter: Lyle DeVore

Race Director: TBD

Track: (518) 587-0220

www.lebanonvalley.com

e-mail: lyle@lebanonvalley.com

AUTODROME DRUMMOND

Physical Address: C.P. 114, 1155, BOUL. ST-JOSEPH OUEST, DRUMMOND, QUÉBEC, CANADA J2B 6B6

Owners: Alain Poirier, Jacques Constant

Assistant Promoter: Yan Bussiere

Race Director: Steve Salvas

Track: (819) 474-2222

(585) 394-0961 www.autodromedrummond.com

e-mail: yanracing21@cgocable.ca

AUTODROME GRANBY

Physical Address: 1268 Rue Cowie, Granby, QUE, CA J2G 9H9

Owners: Dominic Lussier, J.F Tessier

Promoter: Dominic Lussier

Race Director: Steve Salvas

Office: (450) 375-7652

Track: (450) 375-3055

www.autodrome-granby.com

e-mail: dlussier@autodrome-granby.com

BEAR RIDGE SPEEDWAY

Physical Address: 802 Kidder Road, Bradford, VT 05033

Mailing Address: PO Box 273, Bradford VT 05033

Owners: CV Elms/April May Preston

Promoter: CV Elms/April May Preston

Track: (802) 222-4054

Fax: (603) 787-2490

www.bearridgespeedway.com

e-mail: brs@charter.net

BREWERTON SPEEDWAY

Physical Address: 60 US Route 11, Central Square, NY 13036

Mailing Address: PO Box 268, 8280 Sixty Road, Baldwinsville, NY 13027

Owners: John Wight

Promoter: Cory Reed

Race Director: Cory Reed

Track: (315) 668-6906

Fax: (315) 668-6082

www.brewertonspeedway.com

e-mail: creed@brewertonspeedway.com

BROCKVILLE ONTARIO SPEEDWAY

Physical Address: 7214 Temperance Lake Road, Elizabethtown, Ontario

Mailing Address: PO Box 455, Brockville, Ontario Canada K6V 5T1

Owners: Paul & Cheryl Kirkland

Promoter: Paul Kirkland

Race Director: TBD

Track: (613) 345-6324

Fax: (613) 348-1562

www.brockvillespeedway.com

e-mail: tigger@ripnet.com

CANANDAIGUA MOTORSPORTS PARK

Physical Address: 2820 County Road 10, Canandaigua, NY 14424

Mailing Address: PO Box 671, Brewerton, NY 13029

Owners: Ontario County Fairgrounds

Promoter: Jeremie Corcoran

Race Director: Greg Hixson

Track: (585) 394-0961

www.canandaiguamotorsportspark.com

e-mail: jeremiecorcoran@yahoo.com

CORNWALL MOTOR SPEEDWAY

Physical Address: 16981 Cornwall Centre Road, PO Box 632, Long Sault, ONT CANADA K0C 1P0

US Mailing Address: PO Box 502, Rooseveltown, NY 13683

Owners: Ray and Jacques Lavergne

Promoter: Raymond Lavergne

Race Director: Scott Hanton

Track: (613) 938-3945

Fax: (613) 938-2004

<http://www.cornwallspeedway.com>

e-mail: rhf4@sympatico.ca

FONDA SPEEDWAY

Physical address: 1 East Main St. Fort Johnson, NY 12070

Mailing Address: 1 East Main St. Fort Johnson, NY 12070

Owners: Montgomery County Fairgrounds

Promoter: Pete Demitrazek

Race Director: TBD

Track: (518) 842-2580

www.fondaspeedway.com

e-mail: pdemeitrazek@nycap.rr.com

FULTON SPEEDWAY

Physical Address: 1603 County Rte. 57, Fulton, NY 13069

Mailing Address: PO Box 268, Baldwinsville, NY 13027

Promoter: John Wight

Race Director: Cory Reed

Track: : (315) 593-6531

www.fultonspeedway.com

e-mail: creed@brewertonspeedway.com

HUMBERSTONE SPEEDWAY

Physical Address: 1716 Highway 3 East, Port Colborne, ONT CA L3K 5V4

Mailing Address: 10 Broadway Avenue, St. Catharines, ONT Canada L3K 5V4

Owners: Bobby Davidson, Jr.

Promoter: Bobby Davidson, Jr.

Race Director: Bobby Davidson, Jr.

Track: (905) 834-4002

Fax: (905) 935-3464

www.humberstonespeedway.com

e-mail: info@humberstonespeedway.com

LE RPM

Physical Address: 546 Rue De L'Ecole, St. Marcel, De Richelieu, QE CA J0H 1T0

Owners: Dominic Lussier, J.F Tessier

Promoter: Dominic Lussier

Race Director: Jean-Francois Tessier

Office: Track: (450) 880-1920

www.lerpmspeedway.com

e-mail: jftessier@autodromegranby.com

LEBANON VALLEY SPEEDWAY

Physical Address: 1746 US Route 20, West Lebanon, NY 12195

Mailing Address: PO Box 9, West Lebanon, NY 12195

Owners: Howard Commander

Promoter: Howard Commander

Race Director: Howard Commander

Office: (518) 794-9606

Track: (518) 794-9606

Fax: (518) 794-7889

www.lebanonvalley.com

e-mail: heather@lebanonvalley.com

LERNERVILLE SPEEDWAY

Physical Address: 313 North Pike Road, Sarver, PA 16055

Owners: Sarver Racing, LLC

Promoter: Gary Risch

Race Director: Greg Wheeling

Office: (724) 353-3763

Track: (724) 353-3763

Fax: (724) 353-2650

www.lernerville.com

e-mail: grisch@dirtrack.com

MERRITTVILLE SPEEDWAY

Speedway Address: 2371 Merrittville Highway, Thorold, ONT, Canada L2V 4V6

Mailing Address: 117 Cushman Road, St. Catharines, ONT, CA L2M 6S9

Owners: Pete & Nancy Bicknell and Randy & Tracey Williamson

Promoter: Erica Bicknell

Race Director: Doug Leonard

Office: (905) 892-8266

Fax: (905) 346-2519

www.merrittvillespeedway.com

e-mail: ebicknell@cogeco.net

MOHAWK INTERNATIONAL RACEWAY

Speedway Address: 313 Frogtown Road, Hogansburg, NY 13655

Mailing Address: 24 Pike Road, Akwesasne, NY 13655

Owners: Jodi Swamp, Don Thompson Jr. & John K. Lazore

Promoter: John Lazore

Race Director: TBD

Track: (518) 358-9017

www.mohawkinternationalraceway.com

e-mail: mirtrack@yahoo.com

RANSOMVILLE SPEEDWAY

Physical Address: 2315 Braley Road, Ransomville, NY 14131

Mailing Address: PO Box 296, Ransomville, NY 14131

Owners: Atwal Family

Promoter: Tana Robinson

Race Director: Jeff Anstett

Office: (716) 791-3602

Track: (716) 791-3602

www.ransomvillespeedway.com

e-mail: raceransomville@gmail.com

ROLLING WHEELS RACEWAY

Physical Address: 8310 Grant Avenue Road, Elbridge, NY 13060

Owners: Bert Butler & Bill Mendick

Promoter:

Race Director:

Office: (315) 335-1794

Track: (315) 689-3124

Email: www.info@cnyrp.com

SHARON SPEEDWAY

Physical Address: 3241 Custer Orangeville Rd, Hartford, Oh 44424

Owners: Dave Blaney, Jim Weller, Bill abd Ron Kirila

General Manager: Dave Willoughby

Office: 330-772-5481

Website: www.sharonspeedway.com

Email: pr@sharonspeedway.com

WEEDSPORT RACEWAY PARK

Physical Address: 1 Speedway Drive, Weedsport, NY 13166

Mailing Address: PO Box 415, Weedsport, NY 13166

Owners: Al Heinke

Promoter: Jim & Shannon Phelps

Race Director: TBD

Track: (315) 834-3067

www.weedsportspeedway.com

e-mail: weedsportspeedway@gmail.com

Table of Contents:

Preface						
1.0	Definition of Terms				15.5	Chassis/Frame
	1.1	World Racing Group Rules			15.6	Weight
2.0	Membership				15.7	Body
	2.1	Membership Eligibility			15.8	Suspension
	2.2	Conduct			15.9	Roll Cage
	2.3	Series Championship			15.10	Wheels
	2.4	Medical Exemption			15.11	Tires
	2.5	Substance Abuse Policy/Explanation			15.12	Safety
3.0	Personal Safety Equipment				15.13	Other
	3.1	General			15.14	Series Decal and Patches
	3.2	Seat Belts				
	3.3	Protective Clothing		15.C		Sportsman Modifieds
	3.4	Seats			15.1	Engines
	3.5	Helmets			15.2	Fuel, Fuel Cells and Fuel Systems
	3.6	Other			15.3	Muffler and Sound Reduction Devices
4.0	Licenses				15.4	Traction Control Devices
5.0	Racing Event Procedures				15.5	Chassis/Frame
	5.1	Pre-Race Inspections			15.6	Weight
	5.2	Driver's Meetings			15.7	Body
	5.3	Legality			15.8	Suspension
	5.4	Restrictions			15.9	Roll Cage
	5.5	Pill Draw			15.10	Wheels
	5.6	Hot Laps			15.11	Tires
	5.7	Qualifying/Time	Trials/Heat		15.12	Safety
		Mains	Races/B-		15.13	Other
	5.8	Starts			15.14	Series Decal and Patches
	5.9	Restarts				
	5.10	Racing		15.D		DIRTcar Pro Stocks
	5.11	Flag Rules			15.1	Engines
6.0	Scoring Procedures				15.2	Fuel, Fuel Cells and Fuel Systems
7.0	Payoff and Pit Procedures				15.3	Muffler and Sound Reduction Devices
8.0	Provisional and Alternate Starting Positions				15.4	Traction Control Devices
9.0	Racing Programs Special Event Shows				15.5	Chassis/Frame
10.0	Points Breakdown				15.6	Weight
11.0	Penalties, Fine Schedules and Protests				15.7	Body
	11.1	Penalties and Fine Schedules			15.8	Suspension
	11.2	Protests			15.9	Roll Cage
12.0	World Racing Group Appeal Commission				15.10	Wheels
15.0	DIRTcar Northeast Super DIRTcar Series Vehicle Rules				15.11	Tires
					15.12	Safety
					15.13	Other
					15.14	Series Decal and Patches
15.A	Big Block Modifieds DIRTcar Northeast					
	15.1	Engines		15.E		DIRTcar Stock Cars
	15.2	Fuel, Fuel Cells and Fuel Systems			15.1	Engines
	15.3	Muffler and Sound Reduction Devices			15.2	Fuel, Fuel Cells and Fuel Systems
	15.4	Traction Control Devices			15.3	Muffler and Sound Reduction Devices
	15.5	Chassis/Frame			15.4	Traction Control Devices
	15.6	Weight			15.5	Chassis/Frame
	15.7	Body			15.6	Weight
	15.8	Suspension			15.7	Body
	15.9	Roll Cage			15.8	Suspension
	15.10	Wheels			15.9	Roll Cage
	15.11	Tires			15.10	Wheels
	15.12	Safety			15.11	Tires
	15.13	Other			15.12	Safety
	15.14	Series Decal and Patches			15.13	Other
					15.14	Series Decal and Patches
15.B	DIRTcar 358 Modifieds					
	15.1	Engines				
	15.2	Fuel, Fuel Cells and Fuel Systems				
	15.3	Muffler and Sound Reduction Devices		16.0		Drawings
	15.4	Traction Control Devices				

BOLD- 2016 Rule Modification

RED – Rule Emphasis

PREFACE

A World Racing Group, DIRTcar Northeast and/or Super DIRTcar Series event is a competitive racing event which is intended to be conducted and officiated in accordance with the rules herein (the 2016 DIRTcar Northeast and/or Super DIRT Car Series Rule Book). These rules provide the guideline for all events. The rule book may be amended from time-to-time and special rules may be published and/or adjusted at any particular event with the participants receiving prior notification. By participating in these events, all participants agree to comply with these rules and regulations.

The rules are not intended to express or imply the warranty of safety as a result of publication of, or compliance with the rules and regulations as stated herein. The rules are intended to offer a guideline for the conduct and officiating of an event.

The Series Director shall be empowered to permit any reasonable and/or appropriate amendment from any of the specifications and/or procedures herein, or impose any further restriction that in their opinion does not alter minimum acceptable requirements. Revisions to the rules are not intended to express or imply the warranty of safety shall not result from any such deviation or restriction of the specifications, rules and/or procedures. Any interpretation of, deviation from, these rules herein, are left to the discretion of the racing officials and their jurisdiction is final.

Any visible equipment changes and/or performance enhancing changes to previously approved DIRTcar Northeast and/or Super DIRTcar Series racecars and/or equipment must be approved in writing prior to introduction into competition by the DIRTcar Northeast and/or Super DIRTcar Series officials. DIRTcar Northeast and/or Super DIRTcar Series Officials reserve the right to immediately determine the legality and use of any equipment that has not received prior written approval for introduction into competition.

It is ultimately the obligation of each participant to ensure their conduct and equipment complies with all of the applicable rules, as they may be amended from time-to-time. The rules are in no way a guarantee against injury and/or death to participants, spectators, officials and/or others.

1.0 Definition of Terms

The following terms, which appear periodically throughout this Rule Book, have the following meanings:

- A.) “World Racing Group - WRG”** – The trade name and registered mark of the World Racing Group.
- B.) “DIRTcar Northeast and/or Super DIRTcar Series Rule Book”** – The rules in this Rule Book, as they may be amended from time-to-time as provided in Sub-Section 1.1.
- C.) “DIRTcar Northeast and/or Super DIRTcar Series Officials”** – Persons employed by World Racing Group and appointed by World Racing Group to officiate as an employee or independent contractor at an event.
- D.) “DIRTcar Northeast and/or Super DIRTcar Series Supervisory Officials”** – The officers, employees and/or agents of World Racing Group as designated herein and/or in World Racing Group bulletin. World Racing Group may designate additional ‘Supervisory Officials’ in a bulletin and/or verbally from time-to-time. The World Racing Group, DIRTcar Northeast and/or Super DIRTcar Series Supervisory Officials until further notice are as follows;

For All Events:

- World Racing Group DIRTcar Northeast and/or Super DIRTcar Series and/or DIRTcar Series, DIRTcar Weekly Racing Events
Tom Deery, World Racing Group, President
Jeff Hachmann, World Racing Group & DIRTcar Director
Mike Perrotte, DIRTcar Director of Series and Sanctioning
Doug Leonard, DIRTcar Series Race Director
John Nelson, DIRTcar Series (358 Modified, DIRTcar Sportsman Modified and Pro Stock Series) Events
Denis Moquin, DIRTcar Series (358 Modified, DIRTcar Sportsman Modified and Pro Stock Series) Events
Dave Farney, DIRTcar Series (358 Modified, DIRTcar Sportsman Modified and Pro Stock Series) Events
- E.) “Member”** – An individual who has been accepted by the World Racing Group as a Member pursuant to the rules and whose membership has not expired, been suspended, cancelled and/or terminated.
- F.) “Event”** – A World Racing Group sanctioned event. The event includes the race and all ancillary activity leading up to and following the conclusion of the event, including registration/sign-in, inspection (pre and post-race), practice, time trials and/or qualifying and/or participant meetings and it includes events affected by inclement weather and/or postponed dates related thereto.
- G.) “Promoter”** - The individual, partnership, corporation, joint venture and/or other legal entity that, in connection with the Event, is designated as the “Promoter” in the executed Sanction Agreement for the Event.
- H.) “Competitor”** – A driver, car owner, crew member and/or any other person (other than a World Racing Group Official) who participates competitively in a World Racing Group sanctioned racing Event. Whenever the words Competitor, driver, car owner, mechanic, team member and/or crew member are used unless the context indicates otherwise, the term used shall be interpreted to include any driver, car owner, crew member and/or other person assigned to or a member of the same racing team.
- I.) “OEM”** – Original Equipment Manufacturer.

J.) “**Modified, 358 Modified, Sportsman and/or Pro Stock**” – A specified racing vehicle that fits the specifications set forth in this Rule Book.

1.1 World Racing Group Rules:

A.) **Effective Date** – The Rules are effective upon the date of publication by the World Racing Group for any division and/or event, regardless of when a Competitor receives actual notice. “Date of Publication” of the Rules or any amendments thereto is the earliest of distribution from World Racing Group headquarters and/or release to the press.

B.) **Amendment** – The World Racing Group rules may only be amended by publication of an amendment in an issued pursuant to the authority of World Racing Group officials. An amendment is effective upon the date of the publication, regardless when a competitor receives the actual notice.

C.) **Applicability** – World Racing Group issues various rule books, each of which includes in its title reference to a particular World Racing Group sanctioned series or type of event. The rules in each Rule Book are applicable to the Series and/or type of Event set in the title of that Rule Book.

D.) **Interpretation and Application** – If there is a disagreement or dispute regarding the meaning or application of the rules, the interpretation and application of the Officials at the event will prevail.

E.) **Finality of Interpretation and Application** – The interpretation and application of the Rules by Officials at the event shall be final and non-appealable, except as provided in Section(s) 11 and 12 of the rulebook herein. ALL MEMBERS, INCLUDING COMPETITORS AND OFFICIALS, EXPRESSLY AGREE THAT DETERMINATIONS BY WORLD RACING GROUP OFFICIALS AS THE APPLICATION AND INTERPRETATION OF THE RULES ARE NON LITIGABLE, AND THEY COVENANT THAT WILL NOT INITIATE OR MAINTAIN LITIGATION OF ANY KIND AGAINST THE WORLD RACING GROUP OR ANYONE ACTING ON BEHALF OF THE WORLD RACING GROUP, TO REVERSE OR MODIFY SUCH DETERMINATIONS OR TO RECOVER DAMAGES OR TO SEEK ANY OTHER KIND OF RELIEF AS A RESULT OF SUCH DETERMINATIONS, UNLESS THE OFFICIALS MADE SUCH DETERMINATIONS FOR NO PURPOSE OTHER THAN A BAD FAITH INTENT TO HARM OR CAUSE ECONOMIC LOSS TO THE MEMBER, COMPETITOR OR OFFICIAL. IF THE MEMBER, COMPETITOR OR OFFICIAL INITIATES OR MAINTAINS LITIGATION IN VIOLATION OF THE COVENANT, THAT MEMBER, COMPETITOR OR OFFICIAL AGREES TO REIMBURSE WORLD RACING GROUP FOR THE COSTS OF SUCH LITIGATION, INCLUDING ATTORNEY’S FEES. EACH MEMBER, COMPETITOR OR OFFICIAL FURTHER COVENANTS THAT IN ANY LITIGATION BROUGHT AGAINST WORLD RACING GROUP FOR ANY REASON, IF THE LITIGATION IS NOT DISMISSED PURSUANT TO THIS COVENANT THE MATTER WILL BE TRIED BEFORE A JUDGE OF COMPETENT JURISDICTION AND HEREBY WAVES ANY RIGHT TO TRIAL BY JURY IN SUCH ACTION.

F.) **Principal Rule of Interpretation and Application** – The rules are intended to ensure that sanctioned events are conducted in a manner that is as fair as possible for all competitors, consistent with prompt finality in competition results. On occasion, circumstances will be presented that are either unforeseen and/or otherwise extraordinary, in which strict application of the World Racing Group rules may not achieve this goal. In such rare circumstances, the Officials, as a practical matter, may make a determination regarding the conduct of an event, the eligibility of a Competitor or similar matters that are not contemplated by or are inconsistent with the World Racing Group rules, in order to achieve this goal. From time-to-time in particular rules, Official Entry Blanks, Bulletins and elsewhere, World Racing Group may use the term “EIRI” meaning “Except in Rare Instances” to indicate the likelihood that such a determination may be made..

G.) **Special Rules** – Special rules may be made by the World Racing Group Officials for an event. Such special rules shall apply to the conduct of the event if they are published or announced prior to or during the event by means of Bulletin, newsletter, telephone, fax and/or pre-race meeting.

Section 2 - Membership

2.1 Membership Eligibility

A.) **Eligibility** – World Racing Group may, but is not required to accept as a Member, any individual or business entity interested in racing so long as the individual entity has properly and truthfully filed a World Racing Group application, has agreed to abide the rules and paid the required fee as prescribed for membership as a part of the DIRTcar Northeast and/or Super DIRTcar Series.

a.) At any time once a Membership has been approved, the Member by receiving and accepting the Membership Package has agreed to remain a Member in good standing. Any Membership maybe terminated involuntarily and/or suspended and/or voluntarily terminated. The Membership will also

expire each calendar year on the final day of the year – December 31st, and it is required to complete the required application for Membership acceptance in the new calendar year beginning on January 1.

B.) Competitive Eligibility – All drivers competing in on-track activity at any event, including but not limited to practice, time trials, qualifying races and/or the race/feature, must sign a participant waiver form at the designated registration area prior to any on track participation in any World Racing Group sanction event.

C.) Membership Cards

- a.) All DIRTcar Northeast and/or Super DIRTcar Series team Members in good standing, who carry a Membership Card, will be admitted into the pits at the announced price for the event. Membership Cards must be presented for any discounted price.
- b.) Platinum Members, may be extended discounted or complimentary admissions, and does not alter the card holders standing as a Member.
- c.) Each Member is responsible for lost or unauthorized use of the Team Membership Cards. Each time a Card is requested to be replaced a \$150 fee will be charged.
- d.) Corporate Sponsorship, guest cards and/or any other valid membership card may not be used by any race participants, team members, relatives and/or friends of participants.
- e.) Any misuse of the Membership Card(s) will result in the Card being revoked from its listed member.

D.) Restrictions

- a.) Any driver who possesses a current DIRTcar Big Block Modified and/or 358 Modified membership / license will not be permitted to compete in any DIRTcar sanctioned Sportsman Modified, Pro Stock and/or Street Stock event in the current season (2015).
- b.) Driver's that possessed a DIRTcar Big Block Modified and/or 358 Modified membership in the previous racing season (2014) will not be permitted to compete in any DIRTcar sanctioned Sportsman Modified, Pro Stock and/or Street Stock event in the current season (2015). A driver may petition DIRTcar in writing for permission to compete.
- c.) A Pro Stock and/or Sportsman driver may race in a DIRTcar Big Block Modified and/or 358 Modified sanctioned special event (not a weekly event) by invitation only prior to Labor Day and must purchase an upgraded membership for the event. The driver's normal division of competition must not be in competition on the same night at the same track.

E.) Minimum Age Requirement

To be approved, secure and maintain a DIRTcar / Super DIRTcar Big Block Modified Series Drivers Membership a member at minimum must;

- a) **Be at least 14 years of age to participate on tracks less than 5/8-mile in length. Tracks that are 5/8-mile or longer, a participant must be a minimum of 16 years of age.**
- b) **Complete the "Youth Membership Resume and Application" requesting to compete in the appropriate Series and/or Event(s), in addition to any additional requirements, including, but not limited to the required training modules, etc...**
- c) **Execute and deliver to World Racing Group / World of Outlaws such authorizations, releases, applications, consents, waivers, resumes and other documents as maybe required from time-to-time.**
- d) **Be and remain in compliance with the World Racing Group Substance Abuse Policy.**
- e) **Following completion of all documentation, waivers, consents, resumes, other documents and/or training modules, a driver must be approved for competition before eligible to participate in any sanctioned event.**
- f) **Failure to meet any criteria may result in an indefinite suspension from World Racing Group, World of Outlaws, DIRTcar, Super DIRTcar, DIRTcar UMP and/or any sanctioned World Racing Group event.**

2.2 Conduct

A.) General - All Members agree to act in a professional manner as determined by World Racing Group Officials. The professional manner includes, but is not limited to verbal representation, written representation, any representation that may represent the World Racing Group, the DIRTcar Northeast and/or Super DIRTcar Series, the sport of DIRTcar Northeast and/or Super DIRTcar Series racing and/or motorsports in general and/or any affiliates.

- a.) All Members must arrive at Series races in a timely manner so that they may participate in the entirety of the racing event.
- b.) All Members will not be permitted to compete and/or participate while under the influence of any alcoholic beverages and/or illegal substances. If a member is found to be participating in such a

manner an immediate suspension of Membership will be activated as per the definition of the rules in Sub-Section 2.5.

B.) Any member, during an event; a competitor, crew chief, car owner, crew member and/or team representative may be requested to report to the Series Center for consultation with DIRTcar/Super DIRTcar/World of Outlaws and/or World Racing Group officials. The request may be communicated over the one-way radio and/or verbally. Failure to comply with the request will be subject to fine and/or suspension and/or any other action deemed appropriate by World of Outlaws Officials and/or World Racing Group Supervisory Officials.

C.) Parking – As a disciplinary action a driver and/or race team may be parked during and/or after any World Racing Group event. Parking is a directive from a supervisory official that is a directive to cease competition and may include a directive for the competitor(s) to not participate in an event for a set number of laps and/or complete event(s) and/or future events and/or leave the premises in order to promote the orderly conduct of any DIRTcar and/or World Racing Group event. This directive will only be given in extraordinary circumstances by supervisory officials. Parking will not be construed and/or deemed to be a disqualification and/or suspension and/or other “penalty” as referenced in section 11 and is not appealable under section 12 of this rule book.

2.3 Series Championship

A.) Series Championship – The DIRTcar Northeast and/or Super DIRTcar Series will award drivers points as based upon their finish in each Series race as set forth in Section 10 of this rulebook. Series Championship points may include Home Track Bonus Points, or other bonus points as announced.

At the end of the series scheduled season, the World Racing Group shall announce one DIRTcar Super DIRTcar Series Driver’s Champion, 358 Series Champion, Sportsman Modified Champion and DIRTcar Pro-Stock Champion.

The Champions and top finish positions will be awarded championship prize money as posted, based upon their cumulative point total for the series.

B.) Platinum Team Member Status – Each calendar year teams that compete within the Super DIRTcar Big Block Modified Series will be selected to compete as a Platinum Team Member as part of the Series. The teams that are selected will be required to submit and complete all proper documentation. Platinum Team Members may lose their status if they are in violation of any part of the Agreement, which includes the rules as stated herein.

C.) Banquet – Banquet attendance is mandatory, unless extenuating circumstances present themselves, for the receipt of point fund and/or any bonus post season awards.

D.) DIRTcar Home Track Points

- a. **DIRTcar Home Track points will be awarded to a driver competing in Big Block Modified, DIRTcar 358, DIRTcar Modified Sportsman, DIRTcar Pro Stock divisions at a weekly sanctioned DIRTcar track, provided the minimum requirements are met.**
- b. **DIRTcar Home Track Points will begin at the tracks discretion and be awarded until Labor Day weekend each calendar year.**
- c. **For a driver to be eligible to earn a minimum DIRTcar Home Track Award toward the series championship the driver must participate in a percentage of scheduled events at a DIRTcar sanctioned track in the respective division in which the driver is participating in for the championship;**

Super DIRTcar Big Block Modified Series – 75%

DIRTcar 358 Modified Series – 70%

DIRTcar Sportsman Modified Series 50%

DIRTcar Pro Stock Series – 50%

E.) Mr. DIRTcar Best ‘16’ Championship

- a) **The Mr. DIRTcar Best ‘16’ Championship is based on a driver’s season long best 16 finishes in a respective division in any DIRTcar sanctioned event from January 1 until the Sunday of Labor Day weekend each calendar year.**
- b) **In the event a feature event is started during the point window, but may not be completed due to unforeseen circumstances, the event may be completed outside of the established window and the point standings will be completed following the completion of the held over event.**

2.4 Medical Exemption

A.) Any Platinum Driver that is injured and/or has a medical issue that restricts any driver from participation in a Super DIRTcar Big Block Modified Series and/or DIRTcar Northeast event and/or may be unable to compete as a result, that team/driver will be granted a medical exemption. The medical exemption may apply to any sanctioned DIRTcar weekly event and/or Super DIRTcar and/or DIRTcar Series event. The driver may be required at the discretion of the World Racing Group Officials to produce medical documentation.

- a.) In the event of driver medical exemption the driver has a 6-race (or 14-day) grace period, whichever occurs first, to return. If the driver does not return within the specified time period, the driver could forfeit their Platinum Benefits to include but not limited to points, year-end awards and/or the provisional starting positions for the next season. The determination of forfeiture will be at the discretion of Super DIRTcar and/or DIRTcar Northeast and/or World Racing Group Supervisory Officials.
- b.) Platinum member drivers will receive show-up points per each event until the driver is able to resume his/her driving duties.
- c.) Any Platinum member driver and/or team unable to compete because of any unforeseen circumstance, as determined by Super DIRTcar Big Block Modified Series and/or DIRTcar Northeast Officials may qualify for show-up points.

2.5 Substance Abuse Policy/Explanation

A.) Substance Abuse Policy/Explanation – The DIRTcar Northeast and/or Super DIRTcar Series will distribute to all participants and/or members at the beginning of each calendar year a specified Substance Abuse Policy. To be a member in good standing, the policy must be completed and returned. The Substance Abuse Policy is an addition to the ‘reasonable suspicion’ policy. Reasonable suspicion will be determined at the discretion of World Racing Group Officials.

3.0 Personal Safety Equipment – ALL CARS, ALL DIVISIONS

3.1 General

A.) Each competitor is the solely responsible of for the effectiveness and proper installation, per the manufacturer’s specifications, of personal safety equipment and determining it to be adequate for competition at every event. Each competitor is expected to investigate and educate himself or herself for continuing improvement regarding their own personal safety equipment.

B.) Different safety regulations may be in place depending on the local and/or state government rules and/or laws and/or regulations in the specific location of the racetrack. Helmet and seat belt dates and/or specified equipment requirements, worn, utilized and/or otherwise may be different than specified in the DIRTcar rule book. Contact your local track officials for more information regarding this.

3.2 Seat Belt/Restraint System

A.) Each car will be equipped with minimum five (5) point SFI 16.5 or SFI 16.1 approved restraint system, until the date of the belt expiration (two years from the date of manufacturer). Seat belt restraint systems shall be installed and used in accordance with manufacturer’s instructions. Two inch (2”-inch) wide belts that meet the SFI 16.5 and/or SFI 16.1 specifications will be permitted.

B.) Seat belt material should not be permitted to come in contact with any sharp or metal edge, including when the material passes through the seat.

C.) Rolled and/or de-burred and/or flanged edges or anywhere seat belt webbing passes through and may come in contact with abrasive edges are recommended.

3.3 Protective Clothing

A.) All drivers will be required to wear a fire resistant driving uniform meeting minimum of the SFI 3.2A/5 specification and display a valid SFI 3.2A/5 label.

B.) All drivers should wear fire resistant accessories including but not limited to; head sock, under garments, shoes, and socks. All drivers will be required to wear fire resistant gloves. Shoes and gloves will be required to meet minimum of the SFI 3.3 specifications and display a valid SFI 3.3 label.

3.4 Seats

A.) Aluminum and/or carbon fiber-type composite seats only will be permitted. If a carbon fiber-type composite seat is used it must meet the SFI 39.2 ratings. Aluminum seats with an FIA and/or SFI 39.2 rating are recommended. All seats must be mounted to the frame as required by the seat and chassis manufacturer. Full containment seat(s) and/or aftermarket bolt on head restraints are recommended.

B.) All areas surrounding the head should have padding.

C.) A right side head restraint net and/or support are recommended. All head restraint nets should be equipped with quick release mechanisms.

D.) The driver's seat must be securely fastened to the frame and/or cage in six positions with a minimum of six (6) 3/8"-inch bolts. There should be a minimum of four (4) bolts on the bottom and two (2) in the back of the seat. All seats must be a minimum of 1/8"-inch magnetic steel plate under and up the back 4" inches and be as wide as the seat. Only single piece high back type seats will be permitted.

3.5 Helmets

A.) All drivers will be required to wear a full-face helmet with a minimum Snell safety rating of SA 2010 and/or 2015 /or a valid SFI 31.1, SFI 31.2 and/or SFI 31.1 2000 label.

B.) At all times during any event (practice, qualifying and competition) driver's that participate in the Super DIRTcar Big Block Modified Series as a 'Platinum and/or Gold' contracted driver should wear a head and neck restraint system with a valid SFI 38.1 label. For all other DIRTcar competitors a Head and Neck restraint system are recommended. The head and neck restraint system must be mounted and connected to the helmet per the helmet manufacturer and head and neck manufacturer instructions.

C.) Arm restraints are recommended and must be connected and used as instructed by the manufacturer.

3.6 Other General Safety Items

A.) Sharp and/or protruding edges in and around the cockpit will not be permitted.

B.) Windshield screens should be a minimum thickness of 0.090 inch and should be securely fastened to the roll cage.

C.) A clearly marked electrical engine shut off switch within the reach of the driver.

D.) A clearly marked fuel shut off valve, labeled On and Off, must be mounted within reach of the driver. It must be labeled with the word(s) "Fuel Shut Off". Refer to the drawing in the drawing section of this rule book.

E.) SFI-approved and labeled seat, roll bar, knee and steering pads and/or padding is recommended.

F.) All cars must have a driveline U-Joint scatter shields..

G.) All teams must have a fire extinguisher in the rear of their transporter with the car number clearly visible on the extinguisher. The fire extinguisher must be a minimum of 20lbs and is recommended to FFF type chemical and/or DuPont FE-36 and/or equivalent.

4.0 Licenses

A.) Any driver that intends to participate in any racing event must possess a valid membership and also be approved for competition in the Super DIRTcar Series and/or DIRTcar Northeast. Approval for competition will be made by the Super DIRTcar Series and/or DIRTcar Northeast and/or the World Racing Group Supervisory Officials.

B.) Minimum age of participation in Super DIRTcar Series event and/or DIRTcar Northeast Events is 16. Any drivers that are under 16-years of age and seek to participate in any racing event must be approved in advance. Driver must participate in Youthful Driver approval process. The driver must also be approved for competition by the Super DIRTcar Series and/or DIRTcar Northeast and/or the World Racing Group Supervisory Officials.

4.1 DIRTcar Rookie Status

A.) A "Rookie" is determined by the criteria as set forth by Super DIRTcar and/or DIRTcar and/or World Racing Group Officials

- 1.) A "Rookie" is determined by a driver not starting in a division more than six (6) total times during the driver's career. A "Rookie" candidate may not have won and/or been eligible for the Rookie of the Year Award in any prior season within the specific division declared for eligibility. Rookie Status may only move upwards by division, ie; a modified driver will not be a rookie in the 358-Modified, Sportsman or Pro-Stock divisions. A driver may not regress to be eligible for Rookie of the Year in any division.
- 2.) To be eligible a driver must submit his declaration for Rookie of the Year in writing prior to May 1st to receive approval to participate for the award.
- 3.) 2.) The minimum number of races to be eligible for the Rookie of the Year Award will be 50% of the scheduled races as of the season opener, although those competitors not competing in 50% of the scheduled races will remain in the accumulated standings.

- 4) 3.) The Rookie of the Year Standings will be maintained based on the average feature event finish from each event. Driver's failing to qualify for the feature event, but making an attempt to qualify for the feature event, will receive a last place average finish in those events.
- 5) 4.) An Eligibility Panel will endorse Rookie of the Year candidates following the declaration(s) and will also vote on the season ending award to determine the Rookie of the Year. The Rookie of the Year Award will not be based solely in regard to on track performance. The Eligibility Panel will include: the Series Director, Race Director, Series Public Relations, World Racing Group Senior Management, the defending Series Champion and the preceding year Rookie of the Year. The vote will be determined by simple majority. Ties will be broken by another vote.
- 6) 5.) The Rookie of the Year goes to the Rookie driver, who posts the best average finish will be recognized at the season ending championship banquet. The Rookie of the Year Award is a divisional based award and is based on the performance within the division overall to include weekly sanctioned as well as touring series events.

5.0 Racing Event Procedures

The rules as stated herein will cover the rules of the racing event. Super DIRTcar Series and/or DIRTcar Northeast Officials may alter rules of the racing event from time-to-time. Racing event procedures and/or racing event rules are final and non-appealable.

5.1 Pre-Race Inspection(s)

A.) All cars entered and present at any Super DIRTcar Series and/or DIRTcar Northeast Series event that are intended to compete in the racing event, must pass pre-race inspection prior to any on-track activity. Pre-race inspection may take place in a specified area and/or in the regards of space directly at the team's transporter. Refusal to present vehicle or preventing officials from completing pre-race inspection will result in disqualification from that event and possible penalty and fines.

B.) At all Super DIRTcar Series events, only one entry may be presented for pre-race inspection. Multiple cars entered for one (1) driver will not be permitted.

C.) At all Super DIRTcar Big Block Modified Series events, any competitor who competes with a car that does not have a DIRTcar Big Block Modified engine as set forth in section 15.1 of this rule book will forfeit 30-championship points.

5.2 Driver's Meeting(s)

A.) All drivers' or drivers representative, must attend the driver's meeting. A roll call may be taken. Drivers in violation of not attending the Driver's Meeting could face a fine, loss of driver's points, owner's points, relegated to rear of heat race and/or suspension.

B.) The number of racecars starting each event and the number of laps for each event may be announced at the driver's meeting.

D.) Any changes in the basic event night program due to car count, track conditions and/or any other circumstances may be announced at the driver's meeting.

5.3 Inspection Procedures/Legality

A.) Engines, chassis, suspension, ignition/electrical, tires, fuel and/or sound/mufflers may be inspected at any time.

B.) Fuel may be inspected during periodic intervals utilizing a hydrometer and a dielectric tester. If by chance DIRTcar Officials cannot positively identify the proper fuel at the track, all winnings and points of that particular car from that particular event will be held up until the fuel sample is sent to an independent Laboratory for chemical analysis through a fuel chemist. If a fuel sample is determined to be chemically analyzed, all winnings of that particular car from that particular racing event will be held until the analysis has been completed and a determination has been made by the World Racing Group, DIRTcar and/or Super DIRTcar Series Officials. Upon completion of the laboratory findings DIRTcar Officials and/or World Racing Group Supervisory Officials will make a decision.

C.) Super DIRTcar Series and/or DIRTcar Officials may at their discretion, inspect any car entered for competition in any racing event at any time.

D.) Super DIRTcar Series and/or DIRTcar Officials may at their discretion, impound a part/component, engine and/or any other components and/or the complete car for competitive and/or data analysis.

5.4 Post Race Inspection(s)

A.) All cars will weigh as directed by announcement, radio message or posted at the designated Scales, per the weight rule, and track layout. All cars must weigh in immediately following their

Races as directed. Any detour, redirection, mud puddle meandering, may result in disqualification or penalty

B.) The winner must weigh prior to any Winner's Circle Interview or Presentation.

C.) Any detour to the scale, may result in loss of finish position or time. Should any car stop on the way to the Scales, and be touched by anyone other than a Race Official, the Driver may be disqualified. Any car not meeting the minimum weight, after the designated event will lose its time, and or finishing position from that event.

D.) The scales used for the event, provided by the series or the track, will be considered the official scales for the event.

E.) Scales will be available for any team to verify its car weight and determine the scale weight.

F.) Officials will allow a car to re-scale two times by pulling off scale and pulling back on. Reading of the third attempt will become the entered weight.

- a. A flat tire may be changed with a similar wheel and tire where a tire is flat when approaching the scale at the discretion of the head technical official.**

5.5 Restrictions

A.) Once the racing program (in-turn qualifying) has begun on any racing event, the changing of any tire on any corner will be governed by the rule specifications set forth herein in the Tire Section of this rule book.

B.) All work on the racecar, once any event has begun, must be completed in the designated work/pit area unless informed otherwise.

C.) All cars will receive only one (1) opportunity to start each race. If a car needs more than one (1) opportunity, except for safety reasons, during any race, that car must start at the rear of the field in that particular race.

D.) Drivers and/or team members will not be permitted to tamper with track racing surface.

5.6 Entry/Pill Draw

A.) An entry fee may be charged by the Super DIRTcar and/or any DIRTcar Series at selected events, announced prior to the specified event.

B.) All drivers and/or teams entered in any event must draw for a position in time trial qualifying at the designated location. The drivers and/or teams are responsible for their own pill draw. Only one (1) car may be entered per driver in any event.

- a.) At all Super DIRTcar Big Block Series events, drivers must declare at the pill draw whether they are entering as a Big Block or 358 for the duration of the event.

C.) All pills will be drawn prior to the driver's meeting. If a driver and/or team entered and present at the event do not draw, that team will be placed at the end of the qualifying order. In the event that there are no time trials, then the driver and/or team will start at the rear of their specified qualifying race.

5.7 Hot Laps/Practice

A.) All entered cars will hot lap by the time trial/qualifying (group format) order. Example; the first ten (1-10) cars in the time trial qualifying order will hot lap followed (11-20) and so on. The AMB Scoring Transponder must be mounted on the race car prior to hot laps.

B.) If track packing is required. Any car that does not participate will be given only one (1) time trial lap for that event.

5.8 Qualifying/Time Trials/Heat Races/B-Mains

A.) In all events, the driver qualifies. If for any reason, a driver and car match-up in any race is separated, then only the driver is considered qualified.

B.) If a car/team switches cars, for any reason, that car must start at the rear of all races in which that car/team has qualified for on the same day. If, for any reason, a race must be run on a different day after qualifying is completed, the driver may start the race in the earned qualifying position even if not in the car originally presented for qualifying.

C.) Qualifying will consist of a group format time trial session with consecutive timed laps unless otherwise noted. Changes to the qualifying procedure will be at the discretion of the Super DIRTcar Series and/or DIRTcar Officials. Any type of 'wave-off' is not permitted. Once the car enters the racing surface that is their qualifying attempt if the car does not post a time or fails to complete a lap and posts 'no time' they will start last in a heat race.

D.) Qualifying will take place in the order of the pill draw. In events that utilize group qualifying the pill draw will be utilized to establish each qualifying group. Each car and/or team must qualify with their specified group for their own qualifying opportunity. In the event of qualifying one car at a time if the driver misses his qualifying position by more than two spots the late car will take time at the end of the group and will receive only one qualifying lap. The best position a car that does not qualify in its specified group will be 17th position.

E.) The cars and/or teams that are late must be in line before the last scheduled group begins its qualifying attempt. Time trials will be closed once the final group is in line and has started their qualifying attempt and have started their time trial.

F.) In the event of two or more cars post the same time in time trials, the tie breaker will be the fastest other lap time recorded in time trials. If this does not break the tie, the tie will be broken by the qualifying order draw. In the event that one (1) lap qualifying is utilized the tie breaker will be the qualifying order draw.

G.) In the event that a qualified car for the feature is unable to take the initial green, the first non-qualified car will be taken as the alternate starter for the feature event. The original qualified car will not receive points for the feature race. If a qualified car takes the initial green flag and then falls out of the race, there will not be an alternate starter added to the race and the original qualified car will receive only last place points for the feature.

H.) Once any driver has completed their qualifying attempt by taking the checkered flag, that driver must drive to the technical inspection area to scale the car for the minimum weight requirement. (From time-to-time, some events may require scaling the cars prior to qualifying).

I.) In the event of inclement weather, it is at the discretion of the Super DIRTcar Series and/or DIRTcar Series Director and/or World Racing Group Supervisory Officials to alter the qualifying process.

J.) In the event of inclement weather, following the conclusion of time trials each driver present receives show up points.

5.9 Heat Races

A.) All drivers entered in any event will be scheduled to compete in a heat race.

B.) The heat race lineups will be determined by the results of time trials. The fastest time driver in time trials will draw a pill to determine the inversion for the starting position of the heat races.

C.) The number of laps in the heat races and amount of cars transferring from the heat race(s) will be announced at the drivers meeting by Super DIRTcar Series and/or DIRTcar Officials.

D.) All cars that transfer from the heat race(s) must report to the technical inspection area immediately following the completion of their heat race to scale the car for the minimum weight requirement. In the event that a competitor fails to report to the scale area following the completion of the event, the driver will be immediately disqualified from that race, unless otherwise directed by Super DIRTcar Series and/or DIRTcar Officials.

E.) There will be a redraw for starting position amongst the top finishers in each qualifying/heat race. The number of drivers that participate in the redraw will be determined by the number of heat race(s) run during any given event night and will be announced at the driver's meeting.

F.) Any driver transferring from the heat race(s) to the feature race that does not qualify for the redraw will line up for the feature race based upon the driver's finish in the heat race.

G.) Any driver that does not transfer from the heat race(s) to the feature race will be assigned to compete in a 'B'-Main and/or consolation event/race(s).

5.10 'B-Main(s)'

A.) The 'B-Main' race(s) line up will be determined by the finishing order of the heat race(s).

B.) The number of laps of the B-Main will be based on the overall car count for the event and announced at the driver's meeting.

C.) All cars that transfer from the 'B-Main' must report to the technical inspection area immediately following the completion of the race to scale the car for the minimum weight requirement. In the event that a competitor fails to report to the scale area following the completion of the event, the driver will be immediately disqualified from that race, unless otherwise directed by Super DIRTcar Series and/or DIRTcar Officials.

D.) The lineup(s) for multiple day events will be determined once it has been determined how many cars have returned for the second day of competition and announced at the driver's meeting.

5.11 Backup Cars

A.) A backup car may be introduced at any time between qualifying and the start of the A-feature, with permission from the Super DIRTcar Series and/or DIRTcar Director. An additional entry/inspection fee will be due for the introduction of any backup car where applicable. Any such change will result in the driver starting at the rear of the race in which the driver has qualified for. If a driver changes cars after practice, that driver will remain in his drawn position for time trial qualifying. If a backup car is introduced, the car must pass pre-race technical inspection prior to any competition. Once a car has been withdrawn from an event, that car will not be allowed to be resubmitted to competition during that event. If a driver starts the race in a backup car and does not start the event from the rear of the field a penalty may be issued.

5.12 Starts

A.) In some applications, the start of each race may be preceded with an eight (8) minute air horn to begin the eight (8) minute period. The eight (8) minute sound will be followed by another warning four (4) minutes prior to the start of the race. All cars and drivers must be on the starting grid for driver introductions at the completion of the eight (8) minute period. If the driver is not present that driver's starting position will be forfeited and that driver will start from the tail of the field. If more than one (1) driver is late, the drivers will start at the tail of the feature in the order of their qualified position.

B.) The race will begin immediately once the racing surface is clear and the cars are properly aligned in their assigned starting positions. The number of pace laps will be announced at the driver's meeting.

C.) Any driver, team, and/or car, who purposely attempts to hold up the start of any race will be placed at the rear of the lineup and could be disqualified from the event, suspended and/or fined at the discretion of the Super DIRTcar and/or DIRTcar Northeast Series Officials. Any car that needs to be push started must start at the rear of the field.

D.) Once the allotted time (announced at the driver's meeting) allowed for being on the track, ready to race, has expired, any late car will be penalized. Any car that starts after the field has started assembling must start at the rear of the field. This rule may be adjusted from time-to-time, "EIRI", at the discretion of the Super DIRTcar Series and/or DIRTcar Director.

E.) All double-file starts/restarts will take place at a consistent speed, with cars side-by-side in rows of two throughout the field. Consistent speed will be at the discretion of Super DIRTcar and/or DIRTcar Northeast Series Officials. The initial start will take place at a designated area that will be identified at the driver's meeting. Any car out of line and/or passing before the green flag is displayed will be penalized. If an offending car is located on the last row of the starting grid then that car is allowed to restart but will be penalized 2 positions from its finishing position. If the same car commits a second offense it may be disqualified from that event.

F.) In the event that the race is not properly started by the two (2) front row cars, the responsible car(s) may be moved to the second row. Failure to acknowledge and comply with the "move back" signal will result in instant disqualification from the racing event.

G.) The field may accelerate when the green flag is displayed, but the leader is the control car and must fire first. Any passing before the green flag is displayed will not be permitted. Only the leader has the choice to start on the inside or the outside of the front row.

H.) Alternate starters for any race will not be permitted to start any race after the original start has taken place.

I.) If a caution comes out on the original start or before one (1) lap is completed, the car or cars that brought out the caution will lineup at the rear of the field and the race will have a complete restart for the remainder of the field with cars lined up by position at the discretion of the race director.

5.13 Restarts

A.) All restarts will be a double-file after the completion of the first lap of competition in any race. The leader on all double-file restarts will have the choice to start on the inside or outside of the front row. In all restarts lead lap cars will move to the front with lap down cars moving to the tail end of the field. All restarts that take place with 25-laps or less remaining in any feature event will be single file with lead lap cars to the front with lapped cars moving to the tail end of the field. The number of laps and method of restart will be announced at each event's driver meeting held prior to the event.

B.) All restarts will take place with the lead lap cars moved to the front of the field. Lapped cars will pull to the inside and fall in behind the last car on the lead lap in their order of running.

C.) The restart area will be designated at the driver's meeting.

D.) All restarts will take place at a consistent speed. Consistent speed will be at the discretion of Super DIRTcar Series and/or DIRTcar Officials.

- E.)** Passing may begin once the leader accelerates and passes the designated restart point and the green flag is displayed.
- F.)** If a car is not in a proper nose-to-tail alignment and/or is guilty of an excessive gap between cars, then that car may be penalized. If there are multiple violations, the car may be disqualified from the event.
- G.)** If the leader is unable to properly restart the race after the one (1) attempt, the leader will be penalized two (2) positions.
- H.)** When an infraction occurs on a restart, Super DIRTcar and/or DIRTcar Northeast Officials shall exercise their discretion and allow the race to continue, not calling for another restart, and then penalize the offending car(s) under yellow flag conditions or at the conclusion of the race. The offending car(s) will be penalized.
- I.)** Any cars that require a push start during a caution period, will be considered involved in the incident which brought out the yellow flag and that car will have to restart at the rear of the field.
- J.)** Any cars that stop, either on the racing surface and/or in the pit/designated work area, during a caution period will be required to restart from the rear of the field.
- K.)** Any cars that are involved in a red flag situation will be required to restart at the rear of the field, including cars that go to the pits during a red flag situation.
- L.)** Any car that stops due to the red flag being displayed will be permitted one (1) opportunity at a push start provided the car was not involved in the incident. If the car does not fire it will be pushed back to the designated pit/work area and once restarted must start from the rear of the field.
- M.)** Any car that stops because of a blocked track, at the discretion of the Super DIRTcar Series and/or DIRTcar Officials, will not be considered involved in the red or yellow flag.
- N.)** Any car that is black flagged for consultation during a caution period will retain its position only if the Super DIRTcar Series and/or DIRTcar Officials deem the car 'clear' and permit it to return directly to competition without adjustment.

5.14 Racing

- A.)** Any car that does not race on the designated racing surface in order to better its position will be black flagged and penalized at the discretion of the Super DIRTcar Series and/or DIRTcar Officials.
- B.)** Prior to the start of the feature race, on-track, outside the car introductions may be scheduled. In the event of inclement weather and/or other schedules the Super DIRTcar Series and/or DIRTcar director may change this.
- C.)** A pace car may be utilized to pace the field prior to the start of the event and on all restarts. Passing of the pace car, unless otherwise instructed to do so by the Super DIRTcar Series and/or DIRTcar race director, will not be permitted.
- D.)** Any car that spins during green flag racing conditions and is involved in an incident and/or has a problem, but does not bring out the yellow flag and/or create a caution period, will blend back into the field where the driver is able to do so. If there is a caution period the Super DIRTcar Series and/or DIRTcar Officials will determine the placement of the car(s) involved.
- E.)** At the discretion of the Super DIRTcar Series and/or DIRTcar Official any car that is involved in two (2) single car spins that are unaided may be disqualified from the event. If the car spins unaided for third time it will result in automatic disqualification from the event.
- F.)** At the discretion of the Super DIRTcar Series and/or DIRTcar Official any car that intentionally brings out a caution period may be penalized and/or disqualified from the event.
- G.)** All races must be completed in a "green-white-checker" finish. Any race may be extended past its advertised distance with a "green-white-checker" finish. This means if the yellow flag is displayed or caution lights illuminated prior to the leader receiving the checkered flag, that race will be restarted and run for two consecutive laps before completion.
- H.)** If a race is red flagged due to weather conditions and cars are sent to the pits, then any and all work is permitted.
- I.)** Cars that pit during the course of a race for service and/or repair may re-enter the race under green flag conditions once release and instructed to do so by Super DIRTcar Series and/or DIRTcar Officials.
- J.)** Hand signals, colored gloves and pit boards will be permitted during the event for the sole purpose of communicating with drivers. Flashlight and/or two-way radio communication with drivers will not be permitted.

K.) The feature event will be considered a complete event when 50% of the scheduled or announced laps have been completed. E.I.R.I.

L.) Officials may complete an event, at any completed lap count, at their discretion, if a condition or circumstances create a reasonable inability to continue. The race will be considered complete unless announced otherwise.

M.) If, when officials determine in their sole discretion that unforeseen circumstances prevent the completion of the advertised distance or make it impractical to continue or complete the Race within a reasonable time after it has been stopped, the Race will be considered officially completed as of the last lap completed by the leader prior to the Race halt. The finishing positions will be determined, as they would have held if the Race had been restarted.

5.15 General Racing Equipment and/or Requirements

A.) Two-way radios will be permitted at specified events for specified divisions, including events that have and/or include pit stops, whether required or mandatory.

B.) All competitors in all DIRTcar divisions (Big Block Modifieds, 358 Modifieds, Sportsman Modifieds and/or Pro Stocks) are required to have, in working condition, an approved Racing Electronics one-way radio system to aid in line ups and/or the use of race control to manage the racing event.

C.) All cars must have and/or provide the adequate hardware for the attachment of the AMB TRANS X 260 Transponder. Please refer to the drawing/diagram.

5.16 Special Event (Events that require Pit Stops) – Cars, Equipment and/or Procedures

A.) In any event that requires a pit stop and/or refueling, the use of two (2) dump/refueling cans at the same time will not be permitted. Only one (1) dump/refueling can, which may not exceed 12 US Gallons in capacity, will be permitted at one time.

B.) Car(s) may not be pushed past the flagman located at the end/exit of pit road.

C.) Once a race has taken the original green flag and laps have started counting, cars may be started by hand pushing in the pit area and/or on pit road only. Push trucks may be available and will be signaled by race control for a mechanical push start if required. In events that utilize a pit road for servicing the car with a pit crew, push trucks will not be permitted to push start and/or push cars off of pit road and back into competition, unless directed to do so by the Super DIRTcar Series and/or DIRTcar race director.

D.) Cars may only enter pit road for pit stops from the defined pit road entrance. Cars must travel on pit road in a counter-clockwise direction only.

E.) When multiple cars are pitting and enter pit road, they must enter in single file. Passing on pit road will not be permitted. Cars must stay as far to the rights as possible on pit lane before entering the required pit stall and must maintain 'pit road speed' as designated by the pace car on pace laps. Exceeding the pit road speed and/or passing on pit road may result in a penalty at the discretion of Super DIRTcar, DIRTcar and/or World Racing Group Officials. 'Pit road speed' will be in effect for entering and exiting the pit road.

F.) All pit stop service must be completed in the assigned pit stall.

G.) Only six (6) pit crew members will be permitted over the wall to service the vehicle at any time. The use of any additional crew members may result in a penalty. Five (5) pit crew members to service the car and one (1) to handle the catch can. All crew members going over the wall (limit five plus the catch can person), must be equipped with helmets. All fueling personnel (gasman and catch can person) must have a full-faced helmet, fire resistant gloves and fire resistant fire suit and/or a uniform that has been treated with a fire resistant substance. It is recommended that the gasman with dump can and catch can man have a fire retardant apron in addition to the fire retardant suit. This rule applies for both the Super DIRTcar Series and/or Mr. DIRTcar 358-Modified Championship where refueling is required during a pit stop.

H.) In a 200 lap event, there will be one (1) mandatory pit stop any time after the completion of lap 50. During caution periods after the conclusion of lap 50, the caution will remain out to give teams the opportunity to pit and for the field to 'cycle' through required pit stops (a minimum of three (3) laps of caution).

I.) For a pit stop to be considered official, the car must come to a complete stop in its assigned pit stall.

J.) In events where pit stops may be required, pit road will remain closed until the pace vehicle has control of the field. If a car enters pit road prior to pit road being 'opened' the minimum penalty will be that car being placed to the tail end of the field and the maximum penalty will be the loss of one (1) lap. Cars that have been damaged and/or require repairs and/or assistance will be permitted on pit road before it is open, however, if they are able to return to the race, they must restart at the rear of the field.

K.) In an event that requires two-way radio communication, the one-way radio must be used 'in-line' with the two-way radio system.

L.) It is recommended that all teams have a sign posted approximately ten (10') feet in the air in front of the air assigned pit areas displaying their car number and color scheme. The sign should be legible for officials to facilitate the delivery of messages from race control.

M.) In the event of inclement weather and/or unforeseen circumstances that prevent the completion of the advertised distance of the event, the race will be considered official after half of the event has been completed. The car leading at the time of the red flag and/or signal of the event completion, will be considered the winner regardless of whether the car has made the mandatory pit stop before that time.

N.) During post-race inspection at specified events, only the driver, two (2) crew members and the car owner will be permitted in the designated post-race inspection area.

5.17 Flag Rules/Officials Signals

A.) Green Flag:

- a.) When the starter displays the green flag, the track is open for racing.
- b.) The green flag signifies the start of any race and/or time trial run.
- c.) Passing will not be permitted before the green flag is displayed at the designated point.

B.) Yellow Flag:

- a.) When the yellow flag is displayed and/or the yellow caution lights are illuminated, this signifies a caution period.
- b.) When the yellow flag is displayed and/or caution lights illuminated passing will not be permitted unless instructed to do so by Super DIRTcar and/or DIRTcar Northeast Officials.

C.) Red Flag:

- a.) When the red flag is displayed all cars on the racing surface and in the pit areas must come to a complete stop in a controlled manner, while not stopping and/or driving through the area of the incident.
- b.) At the discretion of the Super DIRTcar Series and/or DIRTcar Officials a work area may be designated on the racing surface. All cars will be moved to the designated work area on the racing surface before work begins.
- c.) During any red flag situation all drivers, unless involved in the incident, must remain in their car unless otherwise instructed by Super DIRTcar Series and/or DIRTcar Officials.
- d.) If any car enters and/or moves during a red flag period, including entering the pit and/or designated work area, the car will be penalized a minimum of one (1) lap and will restart the race at the rear of the field.
- e.) If the race is red flagged due to inclement weather conditions work and tire changes will be permitted.
- f.) If the race is 'called' due to inclement weather conditions and/or any other circumstances any car that enters the pits/work area prior to the end of the event, that car will be scored at the rear of the field.
- g.) During any red flag, once the field is stopped, the race director may offer the opportunity for any car to pit by signaling to do so with instruction over the one-way radio. Any car that pits for service during the red flag period will surrender it's running position and have to restart at the rear of the field and/or if the race is cancelled due to inclement weather, the car will be scored behind those cars which did not pit.

D.) Black Flag:

- a.) If the black flag is displayed, then the driver that the flag is being displayed toward must bring their car to designated pit/work area immediately for consultation. The car will not be scored after three consecutive laps of from the point that the black flag originally had been displayed.
- b.) In the event that the black flag is displayed toward a car during a caution period and the car is cleared by Super DIRTcar Series and/or DIRTcar officials, the car will maintain and/or return to its position in the running order of the race as instructed to do so by the officials.

E.) White Flag:

- a.) When the white flag is displayed this signifies that the leader of the race and/or the car that is qualifying has started the last lap of that event.

F.) Checkered Flag:

- a.) The checkered flag signifies the completion of the event. All cars must pass underneath the checkered flag to be scored correctly on the final lap of the event.
- b.) Any race and/or qualifying attempt is not completed until the checkered flag is displayed.

G.) Officials Signals:

- a.) All drivers must obey signals, communications, blackboard(s) and/or any other Official's communications that assist in the direction and facilitation of creating proper lineups and/or the process of completing the event.

6.0 Scoring Procedures

- A.) All races are scored at the designated start/finish line.
- B.) The original starting lineup will be posted by Super DIRTcar Series and/or DIRTcar Officials after the completion of all qualifying events.
- C.) The restart lineups will be derived from the official scorer's lap and line scored sheets. **In the event that there is a discrepancy in scoring to reset any lineup position scoring will revert to the last completed green flag lap to derive the lineup.**
- D.) After the first completed green flag lap, when the caution is displayed all cars that were scored under green flag conditions will hold that scored position with all other cars lining up according to their last completed green flag scored lap. This partial lap will count toward the event's total number of laps. Racing back to the start/finish line will not be permitted and in the event that there is an on-track scoring dispute, the chief scorer will refer to the last completed green flag lap to resolve the dispute.
- E.) A lap will not be scored on the original start and/or any restart unless all cars complete the lap by passing through the start/finish line except for the cars involved in the incident.
- F.) In the event that caution and/or red flag is displayed with the checkered flag simultaneously that race is completed. The cars not crossing the finish line will be scored according to their position in their last completed green flag lap.
- G.) In the event of inclement weather and/or unforeseen circumstances, a race may be called complete short of its entire distance, once it has reached half of the scheduled distance. The race at that point will be scored by the restart lineup.
- H.) In the event of unforeseen circumstances, the specified laps of any race may change from the original posted number of laps.
- I.) All cars are required to be equipped with an AMB tranx260 transponder securely mounted on the specified location. It is the competitor's responsibility to ensure proper installation and working condition of the transponder.

6.2 Handicapping

- A.) The number of cars to be qualified be decided by the track handicapper and announced before the first heat race of each night.
- B.) A driver may attempt to qualify only once during qualifying heats. Any driver may attempt to qualify a second car during the consolation events.
- C.) A driver must drive the last car that the driver qualified for the feature. In the event a driver qualifies a car and the car must be scratched, a driver may switch to a back-up car but must start from the rear of the field.
- D.) In the event of twin features, a driver may use one car in the first feature and may use a difference car in the next feature but must start the second feature at the back of the field if the driver switches cars.
- E.) It is the responsibility of the driver to report driver changes DIRTcar, Super DIRTcar and/or Track Officials.
- F.) Drivers that change cars must start the feature from the rear. Failure to do so may result in a penalty and/or disqualification and/or not being scored in the race.
- G.) Cars and/or drivers must only compete in one division at any given sanctioned event, unless by invitation or with approval from the handicapper.
- H.) The driver must have a current license/membership for each division and/or purchase a single-event license in order to compete.
- I.) For all Super DIRTcar Big Block Modified Series race only: Provisional starting positions will be available in championship series races. A provisional start must start behind all other cars. Provisional starters must have attempted to qualify in a preliminary event in order to start the main event.
- J.) At all Super DIRTcar Series events and selected events for other Mr. DIRTcar divisions, time trials will be used as a basis for qualifying procedures. All drivers will draw for time trial order and/or heat line up.

K.) Points are official when posted on the pit board. If there is a mistake, the owner and/or driver has five (5) days from the posting to protest.

7.0 Payoff and Pit Procedures

A.) All paid purses, appearance money and/or other awards and/or funds as outlined in the promoter's contract shall be paid to the car owner and/or designated owner's representative.

8.0 Provisional and Alternate Starting Positions

A.) If provisionals are permitted in the Feature event; the car(s) will earn full Super DIRTcar and/or DIRTcar Northeast points.

B.) All 2016 Super DIRTcar Series Platinum Member Teams are "preferred provisional starters" provided they attempted to qualify for that feature event. "Preferred Provisional Starts" are limited to four (4) starting positions per season. Any non-platinum member(s) in the top-12 in series may be considered a "non-paid" provisional. After five series races positions 13 through 15 may also carry a "non paid" provisional starting consideration. Only two (2) "non-paid" provisional starters may start a race unless otherwise altered by the Super DIRTcar Series Officials. "Non-Paid" Provisional starters will forfeit last place prize money to start the feature race. The maximum number of provisionals that any one driver may in a single season is four (4).

C.) Any provisional starters will fall in line at the rear of the Feature.

D.) A minimum of four (4) Super DIRTcar Series Championship Point Standing 'paid' provisional positions will be permitted for each Event's Feature.

E.) In the event that provisional positions are not used by any driver attempting to qualify for the feature event and there are no more transfer positions available to have enough positions to fill the number of starting positions for the number of posted starting positions for the race, the remaining available positions open for the feature will be awarded to the next fastest qualifier(s) from time trials, who have attempted to qualify for the feature.

F.) At tracks where a weekly DIRTcar Northeast program is raced and pointed, the promoter may install a promoter's optional starter identically paid and pointed as the Super DIRTcar Series provisional starting positions.

G.) In the event that a car qualified for the Feature is unable to present itself no later than the final pace lap prior to the initial green flag, the first non qualified car will be taken as the alternate for the Feature event. The original qualified car will not receive points for the Feature race. If a qualified car takes the initial green flag and then falls out of the race, no alternate will be taken and that car will receive only last place points for the Feature.

9.0 Racing Programs Special Event Shows

A.) There may be special event shows during the year that do not follow the standard Super DIRTcar and/or DIRTcar racing formats. When such events occur all teams will be informed of specific program and/or procedural changes for that particular event. All racing programs are subject to change and any such changes will be explained at the driver's meeting.

B.) All cars entered in a Super DIRTcar and/or DIRTcar sanctioned event must have the Super DIRTcar and/or DIRTcar Northeast decals and contingency program decals displayed in a visible area on both sides of the car.

C.) From time-to-time mandatory autograph sessions will be scheduled. Drivers will be notified of attendance and location at selected events.

D.) The top ten (10) drivers in the Super DIRTcar Series and/or DIRTcar Championship Point Standings entering the event may be required to be present for the autograph session.

E.) If any driver fails to report to any autograph session a written penalty may be issued, which could result in loss of points and/or fine(s).

10.0 Points Breakdown

Position	Weekly Events	Pre-LD Series Events	Mr. DIRT	Series Grand Slam
1	60	100	60	150
2	56	95	56	140
3	52	90	52	135
4	50	85	50	130
5	48	80	48	125
6	46	76	46	120
7	44	72	44	116
8	42	68	42	112
9	40	65	40	108
10	38	63	38	104
11	36	60	36	100
12	34	58	34	96
13	32	56	32	92
14	30	54	30	88
15	28	52	28	85
16	27	50	27	82
17	26	48	26	79
18	25	46	25	76
19	24	45	24	73
20	23	44	23	70
21	22	43	22	67
22	21	42	21	64
23	20	41	20	62
24	20	40	19	60
25	20	40	18	58
26	20	40	17	56
27		40	16	54
28		40	15	52
29		40	14	51
30		40	13	50
31 - end		40	etc	50
DNQ		10		20

A.) 10 (show-up) points will be awarded to all members in good standing, who attempt to qualify a car, but fail to qualify for the feature event. In certain events there may be 20 (show-up) points awarded.

B.) If a race is cancelled and rescheduled and a member in good standing is unable to return due to extenuating circumstances then that member may be awarded show-up points if they were present and prepared to race on the original date.

C.) If a race is cancelled after time trials have been completed due to inclement weather 'show up' points will be awarded to each driver in attendance.

D.) For Super DIRTcar Big Block Modified Series events, unless otherwise noted, fastest time and qualifying race points will be awarded. The driver posting the fastest time in time trials, 5-points will be awarded. Qualifying race points will be as follows: 1.) 5-points 2.) 4-points 3.) 3-point. 4) 2-points, 5) 1-point

E.) In any DIRTcar Series event(s) where there are a set number of drivers that qualify for the feature event based on time trials, these drivers may not be required to participate in a qualifying race, but will be awarded 5-points for qualifying through time trials. Once a driver is qualified for the feature event through an event that has a set number of drivers that qualify for the feature event through time trials they may not earn in any other points in any other qualifying race and/or event.

F.) In the event that a tie should occur in the final Championship Point Standings at the end of the season, the tie will be broken by referencing and ranking the tied competitors by the greatest number of first (1st) place finishes. If the tie still exists then the tie will be broken by the greatest number of second (2nd) place, third (3rd) place, etc., finishes until the tie is broken.

Bonus Point Schedule:

DIRTcar Overall Point Standings will be computed by adding points earned at Series races to Track Bonus Points, issued after Labor Day Weekend. Track Bonus points are based on a driver's best "home" track standings. Home Track Bonus Points will be awarded on the following schedule

Track Bonus Points for 2016

• 1st	1000	• 14th	922
• 2nd	985	• 15th	920
• 3rd	975	• 16th	918
• 4th	965	• 17th	916
• 5th	955	• 18th	914
• 6th	945	• 19th	912
• 7th	940	• 20th	910
• 8th	935	• 21st	908
• 9th	932	• 22nd	906
• 10th	930	• 23rd	904
• 11th	928	• 24th	902
• 12th	926	• 25th	900
• 13th	924		

11.0 Penalties, Fine Schedules and Protests

A.) The Super DIRTcar Series and/or DIRTcar conducts itself as the top Modified Racing Series in North America and expects its members to conduct themselves in a professional manner at all times during any event and/or when representing the series. **Car Owners, Drivers and Crew Chiefs are responsible for the conduct of their team members and/or anyone connected to or affiliated with that owner's team, in addition to being responsible for all infractions, technical and/or non-technical in nature. In the event that a penalty is issued, only active DIRTcar Members in good standing, have the right to an appeal, if the penalty is appealable.** All fines that are listed in sub-section 11.1 are in regard to the initial penalty. Multiple infractions of the same type will increase the severity of the penalty.

11.1 Penalties and Fine Schedules

- A.) All fines may be collected from prize money on the day of the infraction. If the competitor has not won appropriate money, the fine must be paid in full before the car and/or driver participates in another Super DIRTcar Series and/or DIRTcar sanctioned event.
- B.) Any member that attempts to and/or does physically abuse any event official, including pushing, punching, touching, grabbing and/or grabbing the official's equipment, etc., will be subject to disqualification and/or fine and/or suspension and/or legal action and/or any other action deemed appropriate by Super DIRTcar Series and/or DIRTcar Officials and/or World Racing Group Supervisory Officials. Minimum = \$50; Maximum = \$5,000.
- C.) Any member that verbally abuses any event official will be subject to disqualification and/or fine and/or suspension and/or legal action and/or any other action deemed appropriate by Super DIRTcar Series and/or DIRTcar Officials and/or World Racing Group Supervisory Officials. Minimum = \$50; Maximum = \$2500
- D.) Any member that attempts to push and/or start their racecar off from the wrong area and/or does not stop in the designated area as to cause undue confusion and/or delay will be subject to fine and/or suspension and/or any other action deemed appropriate by Super DIRTcar Series and/or DIRTcar Officials and/or World Racing Group Supervisory Officials. Minimum = \$50; Maximum = \$2500
- E.) Any member who fails to stop for and/or allow post-race inspection will be subject to disqualification and/or fine and/or suspension and/or any other action deemed appropriate by Super DIRTcar Series and/or DIRTcar Officials and/or World Racing Group Supervisory Officials. Minimum = \$50; Maximum = \$2500.
- F.) Any member that attempts to and/or passes the pace vehicle (unless instructed to do so) will be subject to disqualification and/or fine and/or suspension and/or any other action deemed appropriate by Super DIRTcar Series and/or DIRTcar Officials and/or World Racing Group Supervisory Officials. Maximum = \$1000.

- G.) Any member that attempts to drive roughly and/or bumps another competitor unnecessarily will be subject to disqualification and/or fine and/or suspension and/or any other action deemed appropriate by Super DIRTcar Series and/or DIRTcar Officials and/or World Racing Group Supervisory Officials. Minimum = \$50; Maximum = \$5,000.
- H.) Any member that attempts to use illegal fuel will be subject to disqualification and/or fine and/or suspension and/or loss of points and/or any other action deemed appropriate by Super DIRTcar Series and/or DIRTcar Officials and/or World Racing Group Supervisory Officials. Minimum = \$100; Maximum = \$5,000.
- I.) **The following penalty schedule for applies to any “fuel violations”. The penalty schedule will be as follows;**
1. **In the event of any competitor is found to have non-compliant fuel per the DIRTcar Rule Book and/or any issued DIRTcar document, the competitor will be fined a minimum of \$250 for the first offense in the DIRTcar Big Block and DIRTcar 358 Modifieds. A minimum of \$150 in the DIRTcar Sportsman Modifieds and DIRTcar Pro Stock divisions. In addition a competitor may lose up to one half of the points earned for the race and be placed on probation.**
 2. **In the event of any competitor is found to have non-compliant fuel per the DIRTcar Rule Book and/or any issued DIRTcar document, the competitor will be fined a minimum of \$500 for the second offense in the DIRTcar Big Block and DIRTcar 358 Modifieds. A minimum of \$300 in the DIRTcar Sportsman Modifieds and DIRTcar Pro Stock divisions. In addition a competitor will be disqualified from the race and be placed on probation.**
 3. **In the event of any competitor is found to have non-compliant fuel per the DIRTcar Rule Book and/or any issued DIRTcar document, the competitor will be fined a minimum of \$1,500 for the third offense in the DIRTcar Big Block and DIRTcar 358 Modifieds. A minimum of \$1,000 in the DIRTcar Sportsman Modifieds and DIRTcar Pro Stock divisions. In addition a competitor will be disqualified from the race and will be suspended indefinitely.**
- J.) Any member that violates any technical rule as presented within the rulebook and/or issued in a written bulletin will be subject to disqualification and/or fine and/or suspension and/or loss of points and/or any other action deemed appropriate by Super DIRTcar Series and/or DIRTcar Officials and/or World Racing Group Supervisory Officials. Minimum = \$50.
- K.) The penalty schedule for any violations “technical in nature will be as follows;
1. In the event of any illegal internal modification to any Chevrolet Performance Parts Crate Engine and/or DIRTcar Spec Engine and/or tampering of any manufacturer and/or DIRTcar seal a maximum of a 1-year suspension and/or indefinite probation period and/or the engine will be impounded immediately and/or **a minimum penalty of \$3,500 and/or** loss of all earnings based on the current race season, including but not limited to points, point fund awards and/or or race winnings. In the event the driver is suspended from a division utilizing the GM crate engine and/or DIRTcar spec engine, the driver maybe offered the opportunity to move up in division to continue participation after serving a suspension deemed appropriate by Super DIRTcar and or DIRTcar officials. The offer will only come from a World Racing Group supervisory official. This decision is final and non-appealable.
 2. For subsequent violations in regard to any illegal internal modification to any Chevrolet Performance Parts Crate Engine and/or DIRTcar Spec Engine an indefinite suspension will be issued.
 3. For any violation in weight following any scaling process a loss of position, loss of qualified and/or qualifying position, disqualification and/or loss of points and/or loss of purse and prize money awarded and/or suspension and/or probation will be issued and based solely at the discretion of DIRTcar and/or Super DIRTcar and/or World Racing Group officials based on the severity, nature and intent of the violation.
- L.) **Recommended Penalty structure for Scaling Violations;**

a. Any weight violation that occurs following timed hot laps, time trials and/or a qualifying event will eliminate any qualifying result for the violation, with the competitor required to forfeit their qualifying position and start last in the next race. If the next race is the feature, the competitor may use a provisional to the feature race, only if eligible for a provisional starting position. In the event the competitor is not eligible for a provisional, the competitor will not be permitted to start the feature race.

b. For any weight violation under the minimum weight posted the competitor will be disqualified from the event.

- M.) For any other violation that is “technical in nature” the penalty that is issued will be based solely at the discretion of DIRTcar and/or Super DIRTcar and/or World Racing Group officials, based on the severity, nature and intent of the violation.
- N.) For any violation in which a competitor is found to be using an electronic and/or data recording device and/or telemetry and/or device that indicates any form of traction control an immediate indefinite suspension and/or loss of points and/or loss of purse and prize money awarded based solely at the discretion of DIRTcar and/or Super DIRTcar and/or World Racing Group officials based on the severity, nature and intent of the violation.
- O.) Any member that attempts and/or is found to be using tires that are found to be illegal in any manner will be suspect to disqualification and/or fine and/or suspension and/or loss of points and/or any other action deemed appropriate by Super DIRTcar Series and/or DIRTcar Officials and/or World Racing Group Supervisory Officials. The minimum penalty for any (chemically) altered tire will be as follows: disqualification from the event, and/or a fine up to 1,000 championship or track points, loss of all earned purse and/or reward money from the event, a fine equal to and/or more than the purse money rewarded for the event and/or a minimum suspension of 1 month (minimum or 4 races) up to six (6) months in duration.
- P.) Any member that attempts to or uses an illegal motor will be subject to disqualification and/or fine and/or suspension and/or loss of points and/or any other action deemed appropriate by Super DIRTcar Series and/or DIRTcar Officials and/or World Racing Group Supervisory Officials. Minimum = \$500; Maximum = \$5,000.
- Q.) Any member that fails to stop for a red flag or drives through the incident area will be subject to disqualification and/or fine and/or suspension and/or loss of points and/or any other action deemed appropriate by Super DIRTcar and/or DIRTcar Northeast and/or World Racing Group Supervisory Officials. Minimum = \$50; Maximum = \$2500.
- R.) Any member that goes into another competitors pit area or to another competitors car and becomes involved in any type of altercation will be subject to disqualification and/or fine and/or suspension and/or loss of points and/or any other action deemed appropriate by Super DIRTcar Series and/or DIRTcar Officials and/or World Racing Group Supervisory Officials. Minimum = \$50; Maximum = \$5,000.
- S.) Any member involved in an altercation that results in physical contact will be subject to disqualification and/or fine and/or suspension and/or loss of points and/or any other action deemed appropriate by Super DIRTcar Series and/or DIRTcar Officials and/or World Racing Group Supervisory Officials. Minimum = \$50; Maximum = \$5,000.
- T.) Any member who drives a racecar in an area that is closed to racecar traffic or drives through the pit area at excessive speed with either a racecar, scooter or 4-wheeler will be subject to disqualification and/or fine and/or suspension and/or loss of points and/or any other action deemed appropriate by Super DIRTcar Series and/or DIRTcar Officials and/or World Racing Group Supervisory Officials. Minimum = \$50; Maximum = \$2500.
- U.) Any team member who goes out onto the racing surface without permission under a controlled period will be subject to disqualification and/or fine and/or suspension and/or loss of points and/or being placed to the rear of the field and/or any other action deemed appropriate by Super DIRTcar Series and/or DIRTcar Officials and/or World Racing Group Supervisory Officials. Minimum = \$50; Maximum = \$2500.
- V.) Any member who ignores a flag or official signal will be subject to disqualification and/or fine and/or suspension and/or loss of points and/or any other action deemed appropriate

by Super DIRTcar Series and/or DIRTcar Officials and/or World Racing Group Supervisory Officials. Minimum = \$50; Maximum = \$2500.

- W.) Any member who is found to be in violation of the substance abuse policy at any event will be subject to disqualification and/or fine and/or suspension and/or loss of points and/or any other action deemed appropriate by Super DIRTcar Series and/or DIRTcar Officials and/or World Racing Group Supervisory Officials. Maximum = \$10,000.
- X.) Any member who drives or causes to be driven: a race car, pit mule, ATV, 4-Wheeler, personal vehicle or transporter in a dangerous and aggressive manner in the restricted area will be subject to Team Disqualification and/or fine and/or suspension and/or loss of points and/or any other action deemed appropriate by Super DIRTcar and/or DIRTcar and/or World Racing Group Officials. Minimum = \$100.

11.2 Protests

- A.) All protests must be turned into the Super DIRTcar Series and/or DIRTcar Director within ten (10) minutes of the checkered flag and/or conclusion of the race.
- B.) The protest fee must be paid at the time of the protest.
- C.) Only the car owner, the driver and/or the designated team representative of the car owner may turn in an official protest.
- D.) Any refusal of inspection and/or non-compliance during an official protest will result in the disqualification of the protested car and the prescribed penalties.
- E.) If the car protested is found legal, the protesting fees will be released to the protested team less the protest filing fee.
- F.) If the car protested is found to be illegal, the protesting fees will be returned to the team filing the protest less the filing fee.
- G.) Any altercation relating to the incident with Officials and/or any other racing participants by the team filing the protest will nullify the objection.
- H.) **PROTESTING FEES:** (Figures in parentheses are filing fees): Motor tear down involving cylinder head removal and inspection and cylinders inspected; \$750 (\$75): Fuel test including chemical analysis and all other technical protests; \$500 (\$50). **The GM 602 and/or GM 525 Crate Engine motor tear down involving cylinder head removal and inspection of cylinders and other internal components including camshaft and/or crankshaft \$1,000 (\$100). On any crate engine protest, DIRTcar reserves the right to declare where, when and who will inspect the engine.**
- I.) The Super DIRTcar Series and/or DIRTcar Officials reserve the right to ask for a legality test at any time (sealed motor and/or otherwise). If through testing procedures a car is found to be illegal, responsibility for proving otherwise is solely with the team that was checked. There will be no exchange of money for tests asked for by officials when a formal protest is not turned in.
- J.) The Super DIRTcar Series and/or DIRTcar Officials reserve the right to accept or deny any protest based on their sole discretion. 'Grudge' protests and/or any protest that are 'not in the spirit of good standing' will be denied.

Section 12 – World Racing Group Commission:

DIRTcar Racing (World Racing Group, DIRTcar, UMP DIRTcar, DIRTcar Northeast, the World Outlaws, the Super DIRTcar Series and all World Racing Group sanctioned events including but not limited to; DIRTcar, MARS, UMP and/or any of its sanctioned tracks) has established an independent Board to hear and review any penalty determination by MEMBER drivers and owners in a sanctioned event, that has been deemed appropriate for appeal. Only DIRTcar licensed MEMBERS in Good Standing during the current calendar year have the right to appeal.

Section 12-1: Jurisdiction

A.) The World Racing Group Commission may hear appeals of any penalty determination made pursuant to the any of the World Racing Group rulebooks which include, but are not limited to; the Super DIRTcar and/or DIRTcar Northeast, the Super DIRTcar and/or DIRTcar Northeast, the Super DIRT Series, DIRTcar, Mars and UMP.

B.) Only the Member, as the named party to the penalty, shall be able to make a written request for an action to the World Racing Group Appeal Commission.

1. Requests, Appeals, Demands, or correspondence from third parties or any other person, entity, agent, or representative, that is not the named Member as identified in the Penalty Notice, shall not be accepted except as presentation within the administrative hearing process.
2. If a third party submits an appeal request it will subsequently be denied and not be considered as a request.
4. The following deadlines must be met for each series:
 - a. World of Outlaw Sprint Car Series seven (7) calendar days of the issuance of the penalty.
 - b. World of Outlaw Late Model Series seven (7) calendar days of the issuance of the penalty.
 - c. Super DIRT Series events seven (7) days of the issuance of the penalty.
 - d. DIRTcar and/or UMP events seven (7) days of the issuance of the penalty.

A \$250 non-refundable hearing fee must accompany the written request.

The written request and the scheduled fee must be hand delivered via an international recognized courier (the Appellant must obtain and retain a receipt showing date of deposit with courier) to the following for the appeal hearing to be processed:

C/O – World Racing Group Appeal Commissioner
7575-D West Winds Blvd.
Concord, N.C. 28027

Electronically, verbally, or any other type of appeal, including without limitations, faxes, e-mails, and voice mails will not be accepted and processed as an official appeal to the World Racing Group Appeal and Rules Commission

C.) Commission Members:

Paul Kirkland	Gregg McKarns
Cory Reed	Nancy Bicknell
Bob Sargent	Jeff Nuckles
Eric Huenefeld	Erica Bicknell
Daniel Grill	Steve York
Alan Kreitzer	Larry Kemp
Mike Graham	Scott Woodhouse
Scott Boyd	Pete Chuckta
Mark Mockovak	Rollie Helmling

- a. The Chairman of the Commission will be appointed upon approval of the Board of Directors of the World Racing Group. The Chairman shall be an administrative member and will designate an alternate Chairman who shall, in the event of death, retirement, or incapacity of the Chairman, perform the duties of the Chairman until the Board of Directors of the World Racing Group appoints a new Chairman or the Chairman is able to resume his/her duties.

- b. From time-to-time Commission Members may vacate the board, be added and/or adjusted at the discretion of the World Racing Group Commission Chairman.

D.) Meetings – The Commission shall meet at such places and at such times as are necessary for the efficient and prompt disposition of its business. Three (3) members, including the Chairman, constitute a quorum. Meetings may take place with members participating via telephone, teleconference, videoconference, computer conference, in person and/or any other forum as designated by the Chairman.

E.) Hearing Procedures –

- a.) In order for an appeal to be presented to the World Racing Group Commission, the appellant must have standing to appeal. Any decision determined as non-appealable and final during any sanctioned event by Officials employed and/or contracted by the World Racing Group will be considered as a final decision that is non-appealable. Standing is defined as subject matter that is being appealed is not precluded by any Rules as set forth by the sanctioning body and/or specific event and that the appellant has actually been penalized by a decision that is specifically issued to the appellant.
- b.) The World Racing Group Commission will establish and communicate the most appropriate procedure and/or manner for hearing any particular appeal and shall inform all involved parties how to proceed prior to the hearing. Members/appellants may appear in person at hearings before the Commission (but not through a representative or attorney).
- c.) When conducting a hearing and deciding an appeal, the World Racing Group Commission shall not be bound by technical or formal rules of evidence and/or procedure, except as otherwise provided herein, but shall conduct its proceedings in the manner best suited to establishing the relevant facts and the merits of the parties positions.
- d.) Unless contacted by a member of the Commission, the appellant, any competitor, the car owner, car sponsor and/or any other representative(s) involved, may not discuss the subject matter of the appeal hearing with any Commission Member, including the Chairman, outside of the hearing.
- e.) All appeals shall be docketed when received via courier to the Chairman of the World Racing Group Commission and shall be set for hearing at an appropriate time and location as determined by the Commission Chairman.
- f.) The Commission may require/summon, either orally or in writing, in its sole discretion any World Racing Group member and/or official to testify in and/or at a hearing. Any member who is required / summoned to testify and refuses or fails to appear and/or testify may be subject to indefinite suspension or other disciplinary action as deemed appropriate by the World Racing Group Commission.
- g.) If the World Racing Group Commission finds any Member and/or Official to be “in contempt” during a hearing, the Member and/or Official may be subject to indefinite suspension or other disciplinary action as deemed appropriate by the World Racing Group Commission.
- h.) In the event that the Chairman and/or Commission Member is involved in the appeal the Chairman and/or Commission Member shall disqualify themselves from participating as a Commission Member on the appeal and the remaining Members of the Commission shall select a replacement.
- i.) A majority of the members of the Commission / Quorum must concur to modify any penalty (including, but not limited to, imposing different or increased penalties) or determine any appeal. If a majority cannot agree on the action, the appeal shall be referred to the Chairman of the World Racing Group Commission for decision.
- j.) In each appeal the relevant item shall be the accuracy of the decision by the Official(s) in light of the facts and not the results and/or ramifications of the ruling.
- k.) If the World Racing Group Commission determines that the proceedings in respect to any appeal have been instituted or continued without reasonable grounds, the cost of such proceedings shall be assessed against the Appellant who instituted or continued such proceedings.

- l.) The World Racing Group Commission shall have the right (and will) publish the judgment of the Commission and the names of the parties involved. A party shall have no claim or cause of action of any kind against the World Racing Group, the World Racing Group Commission or the publisher.
- m.) If the appeal involves a component of any racing vehicle, equipment and/or any other technical element, the piece(s) will be placed into a chain of custody, until the World Racing Group Commission has heard the appeal and made a decision. A receipt will be given to the Appellant regarding the piece(s) until the conclusion of the hearing. The piece(s) may be confiscated following the hearing as per the determination of the World Racing Group Commission.

F.) Execution of Penalty and Pending Appeal – At the request of the affected Member, the World Racing Group Commission Chairman may determine in the interest of all involved parties that the penalty under review shall be temporarily deferred until the appeal of such penalty has been resolved. Otherwise, the penalty shall be executed promptly. If the Commission temporarily defers execution of the penalty, but later denies the appeal in whole or in part, it may reinstate the original penalty as of the date of issue of the original Penalty and/or Penalty Notice, or take such action as it deems appropriate to effectuate in whole or in part the Penalty and/or Penalty Notice, including disallowance of finishing position, points, or prize money otherwise earned in any Event during the period of temporary deferral of the penalty.

G.) Execution Steps for Hearing:

- a. The decision of the official(s) being appealed shall be put into the record.
- b. The contents of the written appeal shall be put into the record.
- c. The Appellant will put forth their statement to the World Racing Group Commission Chairman and present Commission Members presenting any witness(es) and/or other elements regarding their appeal.
- d. The official(s) will put forth their statement regarding the decision and issuance of the appealed penalty to the World Racing Group Chairman and present Commission Members presenting any witness(es) and/or other elements regarding their appeal.
- e. The Appellant will be permitted to present any rebuttals, additions to the records and/or summations to the World Racing Group Commission Chairman and present Commission Members.
- f. The official(s) will be permitted to present any rebuttals, additions to the records and/or summations to the World Racing Group Commission Chairman and present Commission Members.
- g. At any time during the hearing at the discretion of the World Racing Group Chairman and/or present Commission Members may request information of anyone present at the hearing.
- h. At the conclusion of the hearing, the World Racing Group Chairman and/or present Commission Members will deliberate in private and make any determination, decision and/or recommendation regarding the presented appeal by a majority vote of those members present. The World Racing Group Commission may:
 - reverse the decision
 - modify to increase or decrease penalty
 - uphold the original issued penalty
- i. All interested parties shall be reasonable notified of the Board's decision.

H.) Bond for Costs

- a.) The World Racing Group Commission may require the Appellant to post a sufficient bond to cover the costs of the appeal or any reasonably foreseeable economic impairment presented to the World Racing Group or other Member(s) that might be caused by the appeal. If such a bond is required, its form and substance will be in the discretion of the World Racing Group Commission Chairman.
- b.) The administrative remedies for any appeal included here represent the complete and final process. If the appealing member seeks remedy through the court systems,

the member agrees to the exclusive jurisdiction of the courts in Charlotte, North Carolina for the adjudication of any suit, action or proceeding. All costs and expenses incurred by WRG in responding to the action (including attorneys' fees) shall be borne by the appealing Member.

- c.) If the member initiates within any court whether administrative appeal commission process is completed or in process a suspension penalty, if applicable, may be extended by the time passed to reach the final resolution of the administrative appeal panel and/or any court action.

I.) Finality –

- a. An appeal hearing will be 'heard' if the Chairman, in his sole discretion, determines that the Appellant(s) request is appealable. Matters that will not be heard include; matters where there are no triable facts, frivolity, lack of standing, matters which are not subject to protest or appeal pursuant to the rules, appeals filed in any form of harassment and/or any appeal determined as 'non-appealable' by the World Racing Group Commission Chairman.
- b. The determination of the World Racing Group Commission at the conclusion of any hearing is final and is not for appeal and/or further mediation.

12.2: Chairman Potestas

- A.) In the event that the World Racing Group Commission does not reach a conclusion and/or the appealing member in good standing requests an additional hearing, then the Commissioner Potestas (Dave Stevens) may be considered for assistance and/or a second appeal, Acceptance of the appeal will be at the sole decision of the Chairman Potestas without further board involvement.
 - i. If the Member requests an additional hearing, the Member shall make a written request for such action to the Commissioner Potestas within seven (7) days of the conclusion of the originating hearing.
 - ii. The written request must be accompanied by a \$1,000 non-refundable fee.
 - iii. The written request and the scheduled fee must be hand delivered via an international recognized courier (the Appellant must obtain and retain a receipt showing date of deposit with courier) to one of the following for the final appearing hearing to be processed:
 - 1. C/O – World Racing Group Appeal Post - Commissioner Potestas
 - 2. Corporate Headquarters
 - 3. 7575-D West Winds Blvd.
 - 4. Concord, N.C. 28027
- B.) The Chairman Potestas will determine whether or not the appeal will be heard after reception of the written request and the \$1,000 non-refundable fee and inform all parties involved of the determination.
- C.) The Chairman Potestas may conduct a hearing within a reasonable and practical date, notifying the parties of the appeal and hearing. The Chairman Potestas will determine the date and location (if any) for the Chairman Potestas appeal hearing.
- D.) If requested by Chairman Potestas, Members may be asked to appear in person, but not through a representative and/or an attorney. The subject matter may not be discussed outside the hearing unless specifically contacted by the Chairman Potestas in regard to the appeal hearing.
- E.) Hearings performed by the Chairman Potestas will be conducted according to the procedures disseminated by the Chairman Potestas.
- F.) If the Chairman Potestas determines that the proceedings in respect to any appeal have been instituted or continued by a Member without reasonable grounds, the chairman may disqualify the procedure and such cost, in addition to the appeal fee, shall be assessed against the Member who instituted or continued the proceeding.
- G.) At the request of the filing Member, the Chairman Potestas may determine that the penalty under review shall not be executed until the appeal of the said penalty has been resolved. Otherwise the penalty shall be executed promptly. If the Chairman Potestas temporarily defers execution of the penalty, but later denies the appeal in whole or part, the Chairman Potestas may reinstate the original penalty as of the of the Penalty Notice or take such other

action as the Chairman Potestas deems appropriate to place into effect in whole or in part the Penalty Notice including disallowance of finishing position, points and/or prize money otherwise earned in any Event during the period of temporary deferral of the penalty.

- H.) The Chairman Potestas may require the appellant to post a bond to cover the costs of the appeal and/or any reasonable and foreseeable economic impact to the sanction and/or series and/or other Members that may be caused by the appeal. If the Chairman Potestas requires such a bond, its form and substance shall be at the discretion of the Chairman Potestas.
- I.) The Chairman Potestas may summon, either orally and/or in writing at the Chairman Potestas' sole discretion any World Racing Group Member and/or participant and/or Official to testify at a hearing. Any Member who is summoned to testify in a hearing and fails to do so may be subject to indefinite suspension and/or other penalties as deemed appropriate by the Chairman Potestas and World Racing Group.
- J.) World Racing Group has the right to publish the judgment of the Chairman Potestas and the names of the parties involved. A party shall have no claim and/or cause of action of any kind against World Racing Group, the Chairman Potestas and/or the publisher.
- K.) The administrative remedies for any appeal included here represent the complete and final process. If the appealing member seeks remedy through the court systems, the member agrees to the exclusive jurisdiction of the courts in Charlotte, North Carolina for the adjudication of any suit, action or proceeding. All costs and expenses incurred by WRG in responding to the action (including attorneys' fees) shall be borne by the appealing Member.
- L.) If the member initiates within any court whether administrative appeal commission process is completed or in process a suspension penalty, if applicable, may be extended by the time passed to reach the final resolution of the administrative appeal panel and/or any court action.
- M.) All decision of the Chairman Potestas shall be final.

15.0-A Super DIRTcar Series / DIRTcar Big Block Modified

ANY CAR, TEAM AND/OR DRIVER THAT DOES NOT MEET THESE SPECIFICATIONS AND/OR EQUIPMENT REQUIREMENTS WILL BE SUBJECT TO PENALTIES AS DETERMINED BY THE Super DIRTcar and/or DIRTcar and/or World Racing Group OFFICIALS. **Any new components, including engine components, body designs, frame designs and/or components of any type utilized in competition must be approved by World Racing Group, Super DIRTcar and DIRTcar Officials prior to being introduced into competition.**

15.1 Engines General and Location

- A.) Conventional stock type V-8 engines (OEM American long block – GM, Ford and Chrysler) with the cam in the block will be permitted. Aftermarket DART and Merlin cast iron engine blocks will be permitted.
- B.) A maximum displacement of 467 cubic inches will be permitted with a minimum displacement of 396 cubic inches. An overall maximum tolerance of 10 cubic inches for wear will be permitted.
- C.) Aluminum engine blocks will not be permitted.
- D.) Reverse rotation engines will not be permitted.
- E.) The engine must be centered in the front of the chassis and placed in an upright position.
- F.) Engine set back will be as follows; Minimum is 56"-inches and a Maximum of 66"-inches with a tolerance of ½"-inch (+/-). The setback will be measured from the centerline of the front axle to the rear-machined surface of the engine **where the motor plate is attached to the motor.**
- G.) In the event that there are new engine components and/or a new engine configuration, they must be submitted to World Racing Group Officials and approved prior to being introduced into competition. Only World Racing Group Officials will be able to approve new engine and previously unapproved engine components.

15.1.1 Carburetor

- A.) All engines must be normally aspirated with a single conventional-type four (4) barrel carburetor utilizing Holley components. The metering blocks and the base plate may be altered.
- B.) A maximum of four (4) venturi's will be permitted.
- C.) Fuel injection, nitrous oxide injection, turbo chargers and/or superchargers will not be permitted.
- D.) Fuel and/or air must enter the carburetor through the standard air path / venturi as is typical in a stock OEM carburetor.
- E.) In-line venturi's will not be permitted.
- F.) A minimum of two (2) throttle return springs and a metal toe loop mounted on the gas pedal will be required. The throttle return springs must be mounted in separate locations.

15.1.2 Intake Manifold

- A.) Any single piece American production cast intake manifold that permits the mounting of only one four (4) barrel carburetor will be permitted.
- B.) Only cast aluminum and/or cast iron intake manifolds will be permitted.
- C.) Porting of the intake manifold will be permitted.

15.1.3 Cylinder Heads

- A.) Any design cylinder head manufactured from cast aluminum or cast iron will be permitted. The minimum angle valve angle for any Chevrolet and/or GM type cylinder head will be 18 degrees. Ford and/or Chrysler cylinder head(s) must be approved by

DIRTcar and/or Super DIRTcar and/or World Racing Group Officials prior to being utilized in competition.

- B.) Porting will be permitted.
- C.) Valves must remain in a traditional type pattern, but may be any size.
- D.) Only two (2) valves per cylinder will be permitted.
- E.) Only one (1) spark plug per cylinder will be permitted.
- F.) Titanium valves and retainers will be permitted.
- G.) Hollow stem valves and/or liquid cooled valves will not be permitted.
- H.) The engine must have an operating self-starting mechanism. Vehicles that require a 'push start' will not be permitted.

15.1.4 Camshaft

- A.) Any design camshaft will be permitted, provided the camshaft remains in a stock location in the engine block.
- B.) Chain or belt drives will be permitted.
- C.) Overhead cams and/or similar type applications will not be permitted.

15.1.5 Pistons, Connecting Rods and Crankshaft

- A.) Only aluminum pistons will be permitted.
- B.) Only steel or cast iron crank shafts will be permitted.
- C.) Any design, length and/or make of magnetic steel connecting rods will be permitted.
- D.) Titanium crankshafts and/or connecting rods will not be permitted.

15.1.6 Ignition

- A.) Any type of mechanically driven ignition located in the stock position will be permitted.
- B.) Crank trigger type ignition systems will not be permitted.
- C.) Only one (1) ignition coil and one (1) ignition amplified box will be permitted in the system and on the car.
- D.) Magnetos will be permitted.
- E.) Ignition boxes must remain as manufactured. Internal or external alterations to the ignition amplifier box will not be permitted.
- F.) From time-to-time ignition boxes may be impounded for inspection and/or exchanged and/or analyzed by the ignition amplifier box manufacturer.
- G.) All ignition wiring must remain as designed by the manufacturer and in an exposed manner for ease of inspection.
- H.) One American Passenger Car sized battery with a maximum of 16 volts will be permitted. The battery voltage must not measure more than 16.8 volts. Step up transformer and/or any other device designed to increase voltage will not be permitted.
- I.) The battery must be securely mounted inside the frame rails.
- J.) All cars must have an ignition switch, which is easily accessible by the driver and/or safety crew and clearly labeled ON/OFF in the driver's compartment.
- K.) A battery shut-off switch is mandatory. The switch must be clearly labeled ON/OFF. The switch must be mounted on the left side inner panel (above the steering post). The switch must be outside the panel and easily accessed externally. The switch must be wired to shut off the hot (pos +) side. See diagram in the back of this rule book.

15.1.7 Lubrication/Oiling System/Oil Cooler

- A.) Only a conventional type wet or dry-type oil pump will be permitted. Internal or external pumps will be permitted. Multi-stage dry sump oil pumps driven by a standard belt drive will be permitted.
- B.) One oil tank and one oil cooler will be permitted within the oiling system.
- C.) Only magnetic steel or aluminum oil pans will be permitted.
- D.) Air-type and/or vacuum-type pumps for the purpose of removing air from the oil pan and/or system will not be permitted.
- E.) **The oil pan on conventional DIRTcar Big Block and the DIRTcar 500 engines must have a one (1") inch diameter inspection hole on the left side to permit inspection. If no inspection hole is present the oil pan must be removed for inspection.**
- F.) The oil tank and the oil cooler may be mounted outside the frame rails.
- G.) The maximum capacity of the oil tank must be 14 US quarts.
- H.) The oil tank and the oil cooler must be fully enclosed by the body and must be securely mounted and positively fastened to the frame. Reference the drawing in the back of this rule book for the minimum oil cooler specifications.
- I.) Excessive bracing and/or mounting material will not be permitted.
- J.) Oil coolers mounted outside the external body work will not be permitted.
- K.) Oil coolers must be mounted under the hood or under the side wings/pods. Oil coolers mounted behind the driver will not be permitted. Oil coolers that are not under the hood must have ducting covering them and remain below the bodywork. Unless mounted under the hood the oil cooler must be mounted horizontal and flush with the cut out in the side wing/pod area.

15.1.8- DIRTcar 500

- A.) **The DIRTcar 500 motor is a Developmental Program. Refer to specific bulletins regarding this program in the future.**
- B.) **All 500 engines allowed prior to 2016 must be inspected and approved for competition by DIRTcar technical department.**

15.1.9 – Transmission/Driveline and Driveline Components

- A.) Only approved North American and/or Canadian manufactured manual shift transmissions will be permitted. Automatic and/or automatic-type transmissions will not be permitted.
- B.) Overdrive and/or under-drive transmissions will not be permitted.
- C.) Running through reduction gears will not be permitted. The transmission must be direct drive to the rear end.
- D.) The transmission must have working gears. Forward, neutral and reverse must be working. From the neutral position and with the motor running, the car must be able to go for-ward and/or a backward in a smooth manner. The car must start and move under its own power.
- E.) The transmission must bolt to the bell housing.
- F.) Driveline components made of carbon fiber, titanium and/or other materials (considered exotic) will not be permitted.
- G.) A maximum of two (2) universal joints per driveline will be permitted.

15.1.10 – Driveshaft

- A.) Only one (1) drive shaft connected from the transmission to the center section of the rear end will be permitted.
- B.) Two (2) driveshaft hoops / rings a minimum ¼"-inch thick x 2"-inch wide magnetic steel must be positively fastened by two (2) 3/8"-inch grade 5 bolts to the frame and/or torque arm side plates installed around each universal joint.

- C.) The drive shaft must have some type of drive shaft cover/shield. Cars with open drive shafts must have a drive shaft tunnel a minimum of 1/8"-inch thick magnetic steel extending from 2"-inches under the front edge of the seat to the back of the transmission covering the shaft and the universal joint(s) and output flange on top and both sides. The tunnel must extend down to the floorboards. The cover must be positively fastened with a minimum of four (4) 3/8"-inch diameter bolts at the bottom connected to a cross-member. The cover must be a solid unit with no cuts and/or holes and/or removed material for the purpose of weight reduction. The only hole may be for the gear shift control.
- D.) Closed drive type cars, torque tubes and/or bells that already have a 360 degree cover from the universal joint back to the seat will be permitted.
- E.) **Carbon fiber, titanium, and/or other materials (considered exotic) will not be permitted anywhere in the car.**

15.1.11 – Engine Cooling System/Radiator

- A.) Only one (1) radiator will be permitted. The minimum width of the radiator will be 20"-inches when measured from the outside edge(s) of the radiator. The radiator must be mounted vertically in front of the engine. The minimum height of the radiator must be 22"-inches when measured from the bottom of the frame rail vertically and may incorporate the oil cooler to achieve the vertical height. Radiators mounted on an angle will not be permitted.
- B.) Plastic and/or carbon fiber radiators will not be permitted.
- C.) Auxiliary cooling tanks and/or overflow cans and/or canisters will not be permitted in the cockpit.
- D.) The cooling fan for the radiator must be mounted in the stock OEM location on the front of the water pump. Fans mounted to the crankshaft will not be permitted. Electric fans and/or water pumps will not be permitted.

15.1.12 – Rear End

- A.) Only competition type rear ends will be permitted.
- B.) Hypoid-type and/or Nine (9") Ford-type and/or limited slip-type and/or lockers and/or two speed rear ends will not be permitted. No Non Quick Change Rear Ends Allowed.
- C.) **Only aluminum and/or magnetic steel spools will be permitted.**
- D.) Only steel and/or aluminum rear spindles will be permitted. If the rear spindle is machined from aluminum it must be a one-piece tube and spindle with a minimum outside diameter 2-7/8" and a maximum 2-1/2" inside diameter.
- E.) Live rear ends with aluminum and/or steel axles will be permitted.
- F.) Carbon fiber, titanium and/or other materials (considered exotic) for any rear end component will not be permitted.
- G.) A maximum rear end offset of 4"-inches from the center of the inside tire width when measured from the inside of the left rear tire to the inside of the right rear tire at axle height. Refer to the drawing at the back of this rule book.

15.2 Fuel, Fuel Cells and Fuel System

- A.) All cars must have fuel cells that meet and/or exceed SFI 28.1/2 and/or FT3 specifications and must be not be older than five (5) years from the date of manufacture. The fuel cell must have a maximum capacity of 24.5 US gallons and must remain in a rectangle and/or square shape for measuring and calculating capacity. The fuel cell must be mounted securely in its container and centered between the frame rails. Pressure tanks on fuel systems will not be permitted. Auxiliary fuel tanks will not be permitted. No dry ice or any other cooling agents will be allowed on the motor during competition.
- B.) The maximum capacity of the fuel when measured empty and/or dry will be measured in cubic inches utilizing the standard formula of length (minus 1/2"-inch) x width (minus 1/2"-inch) x depth (minus 1/2"-inch) will be 5,660 cubic inches.

- C.) The foam in the fuel cell must remain unaltered. A minimal cut in the foam will be permitted in the shape of a square or a rectangle. The cut may be no more than 1,000 square inches. The foam must retain the factory cut.
- D.) The fuel cell must be enclosed completely in a rectangle and/or square container that is a minimum thickness of 20-gauge magnetic steel. An aluminum container may be used as an option and must be a minimum of .060"-inch in thickness. On the bottom of the fuel cell, a piece of .090-gauge material (aluminum and/or magnetic steel – in addition to the existing container) must be used at the bottom of the fuel cell container to prevent bowing and/or deflection. The .090-gauge material must have an inspection hole drilled near the center of the piece to measure the thickness of the material. A 1"-inch x 1"-inch x .0625"-inch thick magnetic steel square tubing rack must be fabricated on the top, front and rear sides of the fuel cell container. The square tubing must be a minimum of 5"-inches from the outside edge of the fuel cell on either side. The rack may be fastened to the bottom of the fuel cell can utilizing a piece of magnetic steel angle material that is a minimum of 1"-inch x 1"-inch with a minimum material thickness of .065"-inch magnetic angle steel that is on all four (4) sides of the container. Drilling multiple holes and/or any attempt to lighten any piece within the fuel cell container and/or rack will not be permitted. The measurements taken in regard to the fuel cell container will be measured on an inside-to-inside basis. A tolerance for material thickness will be calculated and permitted for dimensions, however there will be no tolerance for expansion and/or containers that are larger than the minimum.
- E.) For Super DIRT Week and Specified events only:**
- a. The car must come to inspection with the fuel cell exposed for the purpose of inspection and sealing. The fuel cell can bolts must be tight and the bolt heads must be drilled for the purpose of a DIRTcar seal. The filler plate and the bolts that hold the can together will be sealed.
- F.) The fuel cell and/or the container material around the fuel cell must not be able to expand in any way. Tank panels that are bowed and/or bellied and/or positioned to create additional capacity of the fuel cell will not be permitted. Oversized filter housings, fuel coolers, oversized lines, fuel logs and/or any other device that increases the capacity of the fuel system will not be permitted.
- G.) Only one (1) fuel filter with a maximum capacity of one (1) US quart will be permitted with one (1) carburetor fuel log with a maximum outside diameter of 1-1/2"-inches. The fuel log must remain straight without bends and/or curves and must be a maximum of 16"-inches in length. Plastic and/or glass fuel filters will not be permitted.
- H.) Fuel coolers of any type will not be permitted. No dry ice or any other cooling agents will be allowed on the motor during competition.
- I.) The entire fuel cell container must be visible for ease of inspection.
- J.) The fuel cell must be mounted behind the driver rear axle between the rear tires, a minimum of 4"-inches ahead of the rear bumper.
- K.) The fuel cell must be mounted with a minimum of two (2) .125"-inch thick steel straps a minimum of 1"-inch wide. The straps must cover the entire cell. Fuel cells that are mounted in a square tubing frame will be permitted. A minimum of 5/6"-inch ASTM Grade 8 bolts must be used to mount the fuel cell to the frame.
- L.) The bottom of the fuel cell container must be a minimum of 12"-inches from the ground.
- M.) A horizontal bar a minimum of 1"-inch in diameter and .095" in wall thickness must be mounted behind the fuel cell.
- N.) The fuel pick up must be positioned on the top of the fuel cell and be constructed of metal. The vent line must have a check valve.
- O.) Only 'D'-type VP Racing Gasoline, the official fuel of DIRTcar will be permitted for competition. **VP D-113 or D-12** will be the only specified fuel permitted at any sanctioned DIRTcar and/or Super DIRTcar Series event. Blending of fuels, including VP spec (including 'D') fuels of different octane will not be permitted. Alcohol, methanol, nitrous oxide, nitro-methane and/or propylene oxide will not be permitted. Fuel may be

subject to inspection and testing at any time. Proof of purchase for the official fuel of DIRTcar may be required.

- P.) For the purpose of inspection, the driver and/or crew must be prepared to drain fuel upon request for inspection and/or measurement.
- Q.) Only mechanical and/or belt driven fuel pumps will be permitted. Fuel injection system(s) and/or electrical fuel pumps and/or any type of pressurized fuel system will not be permitted.
- R.) A #10 line will be the maximum size fuel line permitted.

15.2 Fuel, Fuel cells and Fuel System for Events that require a Fuel stop

- A.) The quick fill connect must be located in the upper corner of the left rear quarter panel.
- B.) **The maximum filler spout size is 4-1/4 inches outside diameter by eight (8) inches long, then tapering over the next 8-1/2 inches to 3 inches diameter extending to an overall length of 18 inches.**
- C.) The filler tube must take a straight and direct route to the fuel cell from the quick fill connect. **Quick fill tubes constructed of aluminum a maximum 3 inches in diameter will be permitted. A minimum of six (6) inches of 3 inch maximum inside diameter flex hose must be used between the end of the filler spout and fuel cell neck.**
- D.) Only one fuel filler tube is permitted with a maximum outside diameter of 3"-inches.
- E.) When a quick fill device is utilized there must be a vent line with a maximum inside diameter of 1-1/4"-inches. The fuel vent line must take a straight and direct route from the fuel cell to the quarter panel and must be able to accept a catch-can with a one-way check valve.
- F.) **The one-way check valve must be a standard manufactured product available to everyone. If check valve is not listed in a catalog with a part number and price it is not legal.** The fuel vent line must positively fasten to the left rear corner of the rear panel
- G.) The catch can man may not stand behind the rear bumper of the car during pit stop refueling.
- H.) Any fuel lines quick fill and/or fuel vent lines must not be visible from behind the car and must be contained within the rear panel which must be symmetrical in size and shape.
- I.) Onboard fire suppression systems are recommended.
- J.) For the Official Fuel of DIRTcar; the fuel provider's decals must be displayed on both sides of all DIRTcar racecars and a patch is required on the drivers uniform. Logos and/or the presentation of any other fuel manufacturer and/or fuel refinery on the racecar and/or drivers uniform will not be permitted.

15.3 Exhaust - Muffler and Sound Reduction Devices

- A.) Each car must have one (1) unaltered muffler per exhaust.
- B.) The exhaust must exit past the driver and the exhaust must flow toward the rear of the car in an upward manner away from the racing surface. Exhaust systems that face the outside of the car will not be permitted.
- C.) Each muffler must have a tail pipe that is a minimum of 10"-inches long when measured off the rear edge of the muffler.
- D.) Cross-over and/or the joining of exhaust systems from side-to-side will not be permitted.
- E.) Any manufacturer of exhaust header is permitted, but the header material must be magnetic steel and/or stainless steel.
- F.) The permitted mufflers include: Dynomax part number: 17224, 17539 and 17628; Extreme Muffler part number(s): 31530, 31535, 31230, 31235, 30830 or 30835; Beyea part number(s): MUF3DM and MUF3.5DM.

- G.) Several tracks have a locally enforced decibel rule, which preempt any particular muffler rule. Some tracks may have a maximum sound level rule of 95 decibels at 100 feet. This rule will be enforced by local government agencies. Such decibel rules preempt utilizing the required mufflers in sub-section 15.3.

15.4 Traction Control Devices

- A.) All electronic and/or computerized wheel spin and/or ignition retardation and/or acceleration limiting and/or traction control devices of any type will not be permitted.
- B.) Adjustable ping control devices, dial a chip controls, timing controls and/or automated throttle controls will not be permitted.
- C.) Adjustable restrictor plates will not be permitted.
- D.) Remote control components of any-type will not be permitted.
- E.) Radios and/or devices for transmitting voice and/or data will not be permitted, unless otherwise authorized prior to any event.
- F.) Data acquisition systems will not be permitted.

15.5 Chassis/Frame

- A.) All frames must be fabricated utilizing 2"x4" rectangular magnetic steel tubing with a .120" wall thickness. Only 2"x4" rectangular box frames between the front and rear axle centers will be permitted. The 4"-inch side of the rectangular tubing must remain in the vertical position. For the purpose of inspection one 3/16" diameter hole may be drilled in each frame rail. Other holes will not be permitted. Round tubing must be either 1-1/2" outside diameter and/or 1-3/4" outside diameter with wall thickness of .095"-inches.
- B.) Frame width will be as follows; At the front shock towers a minimum 24" and a maximum of 35"-inches. Rear of the car is a minimum of 26" with a maximum of 35"-inches. The minimum frame width at the rear roll bar must be 26"-inches. All measurements will be taken from the outside of the frame rails, at the top and bottom of the frame rails and its longest length. Clips, sub-frames, etc., will be considered a part of the frame.
- C.) The minimum length of the 2"x4" frame rails begins 14"-inches in front of the centerline of the rear axle and extends to the front of the radiator. The left and right rails (both top and bottom) must be equal in distance from the driveline centerline along the total length of the frame. Offset frame rails will not be permitted. A maximum 4"-inch indent in the lower left rear frame rail for suspension clearance will be permitted. The two (2) upper frame rails in the engine compartment may be altered for engine clearance only.
- D.) The kick-ups must meet the same specifications as the roll cage and/or frame material.
- E.) Titanium and/or carbon fiber material(s) will not be permitted on the chassis and/or frame.
- F.) There must be a minimum of 2-1/2"-inches ground clearance from the chassis at its lowest point.
- G.) Metal, lexan, rubber air dams, fins, spoilers, skirts and/or air directional devices underneath the car will not be permitted.
- H.) Ground effects will not be permitted.

15.5.1 – Seat Location and Mounting in Frame

- A.) The seat and steering wheel must be centered in the frame. Offset mounting of the seat and/or steering wheel will not be permitted.
- B.) The bottom rear of the seat must be a maximum of 16"-inches from the centerline of the rear axle. Refer to the drawing at the back of this rule book.

15.6 Weight / Ballast

- A.) All cars will be weighed with the driver seated in the car.
- B.) The minimum weight permitted before and/or after an on track event will be measured by the track scales. The track scales will be the official scales.

- C.) All cars found to be light prior to any event, time permitting will be allowed to make the necessary adjustments and represent themselves at the scales.
- D.) The number of cars to be weighed after an event will be announced at the driver's meeting and/or on the one-way radio. If a car is signaled to go to the scales in any fashion and does not report to the scales at the appropriate time, that car may be disqualified from the event.
- E.) Any car that is found to be light following time trials and/or a qualifying event will be disqualified from that particular race and may make the necessary adjustments and represent themselves for that car's assigned consolation event.
- F.) If a car is found to be light after the feature event, that car may be disqualified from the event.
- G.) Vehicle minimum weights:
 - a. All Big Block Modifieds utilizing a Big Block engine per this rule book must maintain a minimum weight of 2,500 lbs following the completion of any event.
 - b. All Big Block Modifieds utilizing a DIRTcar 500 Big Block engine per this rule book must maintain a minimum weight of 2,500 lbs following the completion of any event.
 - c. All Modifieds utilizing a DIRTcar 358 Modified engine with the Brodix "Spec" heads, ported intake and "tri-y" exhaust must maintain a minimum weight of **2,500** lbs following the completion of any event.
 - d. All Modifieds utilizing a Brodix "Spec." DIRTcar 358 Modified engine with the stock intake manifold (reference 15.3.A.; 15.1.3; 15.1.2 A.) and spec. Schoenfeld headers and a steel or aluminum oil pan must maintain a minimum weight of **2,400** lbs following the completion of any event.
 - e. All Modifieds utilizing a ported steel head DIRTcar 358 engine per this rule book must maintain a minimum weight of 2,650 lbs following the completion of any event.
- H.) During any Super DIRTcar Series Big Block Modified event a weekly 358 and/or Small Block DIRTcar sanctioned track, the home track DIRTcar legal 358 Modifieds will be permitted to weigh their normal small block weight. To be eligible for this, cars must abide by all 358 DIRTcar rules and be in the track's top-25 in weekly point standing and have competed in a minimum of 80% of the track's completed 358 and/or Modified events to date.
- I.) For weekly racing events combining DIRTcar 358 and DIRTcar Big Block Modified the track may establish a weight rule to balance the DIRTcar 358 and DIRTcar Big Block Modifieds in competition. Super DIRTcar Series and/or DIRTcar Officials must be notified and grant permission for such a rule.
- J.) Any small block (short block in length) running with the Big Block Modifieds may only have a maximum engine displacement as specified by the DIRTcar 358 engine rules and the car must follow all DIRTcar 358 Modified rules.
- K.) All weights and/or ballast must be positively fastened and mounted within the vertical planes formed by the frame rails and must remain stationary during competition. All weight(s) must have a minimum of two (2) ½"-inch diameter, grade 5 bolts and/or studs passing completely through the weight. Bolts and/or studs must be anchored to a suitable clamp to fasten it to the frame. Bolts and/or studs welded to the frame will not be permitted.
- L.) All weights must be painted white and clearly labeled with the car number on it. For the period of one event, competitors may label their weight with white duct tape with the car number clearly labeled on the duct tape.
- M.) Ballast and/or weight may not be mounted to the roll cage above the rear deck.

15.7 Body

BODY STYLE AND DIMENSIONS

ALL MEASUREMENTS WILL BE TAKEN WITH DRIVER AND/ OR WITH OR WITH OUT FUEL. TOLERANCE PERMITTED ON ALL BODY DIMENSIONS IS MAXIMUM OF +/- (PLUS OR MINUS) ½"-INCH (ONE-HALF INCH). THIS IS A TOLERANCE, NOT A DIMENSION THAT IS INTENDED TO BE ADDED TO THE BODY DIMENSIONS.

15.7.1 General Body

- A.) Mirrors and/or reflective devices will not be permitted.
- B.) Super DIRTcar and/or DIRTcar Series Officials reserve the right to request body and/or sheet metal to be replaced and/or painted if it has any sharp edges and/or does not appear presentable. Presentable is at the discretion of the Series Official.
- C.) The maximum rear spoiler height, regardless of ride height, may not exceed 50"-inches. The rear spoiler must be able to provide the driver following a view of the track ahead.
- D.) A full magnetic steel windscreen and/or rock guard is required. The windscreen and/or rock guard must have an individual hope opening of 2" x 1" with a minimum of 1/16" thickness. Chicken wire type and/or aluminum screens will not be permitted. The windscreen and/or rock guard must cover the entire windshield area across the front of the roll cage and from the top of the roll cage down to the base of the cowl and/or hood. In addition clear lexan-type and/or safety glass windshields will be permitted. If the lexan and/or safety glass is utilized it must be shatterproof and mounted behind the windscreen and/or rock guard. Any additional windshield must not obstruct the driver's exit of the vehicle.
- E.) The minimum size opening for the side windows will be 12"-inches in height by 18"-inches in width by 30"-inches in depth. A rectangular box, matching these dimensions may be used to pass through the car from one side window through to the other.

15.7.2 Body Material

- A.) Only magnetic steel and/or aluminum will be permitted for all inner and outer body panels.
- B.) Vertical material (plastic and/or rubber-type), with a material thickness between .090"-to-.125"-inch and a minimum height of 8"-inches from the bottom of the quarter panel will be permitted, provided both doors and/or quarter panels maintain the same length and height with or without the plastic (symmetrical). An overlap of two (2") inches to secure the door(s) extensions will be permitted. The door(s) must maintain a minimum of six (6") inches of ground clearance including the additional material extending below the metal body. The overall dimensions of the door(s) and extensions must meet the specifications.
- C.) Only a single piece fiberglass roof will be permitted.
- D.) Only fiberglass and/or aluminum hood, hood scoop, windshield cowl, rear interior tire clearance cover will be permitted.
- E.) Only clear lexan will be permitted for the rear spoiler and rear wing windows. Decals and/or lettering will not be permitted on the rear spoiler and/or rear wing windows.

15.7.3 Roof

- A.) A one-piece fiberglass roof, single ply, one contour inside and out will be permitted. Carbon fiber and/or any other composite type materials will not be permitted. All roll bars must remain exposed. Vertical material of any type used to mount the roof that may cover the roll bar will not be permitted. The roof must weigh a minimum of 10 lbs.
- B.) The roof must be centered from side-to-side on the roll cage and on the frame. Offset bodies will not be permitted. The leading edge of the roof must be positively fastened in a stationary position a minimum of 33"-inches and a maximum of 48"-inches in front of the rear axle centerline. The roof must be securely and positively fastened on all sides.
- C.) The minimum length of the roof is 48"-inches with a maximum of 60"-inches. The minimum width of the roof is 48"-inches with a maximum of 52"-inches. The roof must be of the turtleback style and shape with a minimum of ¾"-inch belly from front-to-rear and ¾"-inch from side-to-side. The roof -contour must fit the DIRTcar roof template patterns. Flat roofs will not be permitted. The maximum front lip must be ½"-inch. The maximum

side edge(s) must be 1-1/8"-inch break. Refer to drawing (NUMBER) on page (NUMBER).

- D.) Changes to the shape and/or location of the roof at any time during competition will not be permitted.
- E.) The maximum overall height of the car is 62"-inches with a minimum of 53"-inches measured from the ground.
- F.) The maximum roof angle is 5 degrees when measured with the DIRTcar gauge. (See reference drawing).
- G.) Any proposed roof design that deviates from the preceding rules must be submitted to DIRTcar for approval and approved before being presented for competition.

15.7.4 Front Door Posts

- A.) Only a one (1) piece magnetic steel and/or aluminum front door posts and/or 'A'-pillars a minimum of .050"-inches with a maximum of .090"-inches will be permitted. The front door posts must be securely mounted the roof and to the door(s). The side of the front door post must measure a minimum and maximum of 2"-inches. The front door post may be bead rolled and/or have a lip and/or flange for re-enforcement, but the re-enforcement must not exceed a maximum 3/8"-inch., in width.
- B.) The door post may be fastened with a minimum of two (2) 3/16"-inch bolts to the door bracket for ease of fabrication.
- C.) Additional material, air directional devices, lexan vent windows and/or excessive material will not be permitted in the corner of the front door post, where the post meets the door panel. Any additional material, air directional devices and/or vent windows must be a maximum of 10"-inches in length.
- D.) There will be no tolerance on the front door post measurements.

15.7.5 Rear Wing Windows / Side View / Rear View

- A.) All rear wing panels and windows must resemble a current production OEM style body. Only manufacture approved rear wing panels and windows will be permitted for competition. Any non-manufacture rear wing panel must resemble and/or meet the criteria as the submitted rear wing panels and/or windows. Any rear wing panel that is submitted for competition must not exceed 815 square-inches in total area. **All rear wing panels must be submitted for approval prior to introduction into competition.**
- B.) The upper profile must not extend above a straight line projected from the rear of the roof to a point 3"-inches higher than the rear deck. A minimum 2"-inch indent in the profile, so as not to make the panel a fast back is mandatory. (Please refer to the drawing and photographs)
- C.) The maximum base length will be 61"-inches. The left and right must be of the same style and dimensions (symmetrical). (See example of Body Style Drawing)
- D.) All rear wing(s) must have an opera-type window. The window must be lexan. Bends or breaks in the Lexan area of the window will not be permitted.
- E.) Only one break as a change in body line/contour will be permitted in the rear wing panel.
- F.) Decals and/or lettering will not be permitted on the rear wing windows.
- G.) The rear view of the wing window must go in a straight line from the top of the quarter panel (tangent) or bodyline to the roof with a maximum gradual bow of 2"-inches in the center of the wing window.
- H.) **Flanges and or additional material added to the rear wing panel for the purpose of directing air flow will not be permitted.**

15.7.6 Body Width and Ground Clearance

- A.) The body width, when measured at any point along the body line from front-to-back will be a maximum of 68"-inches and a minimum of 64"-inches.
- B.) A minimum chassis ground clearance of 2 1/2"-inches will be permitted.

- C.) Fan and/or ground-effect cars will not be permitted.
- D.) Rubber skirts, fins, air directional devices and/or spoilers of any type under the car will not be permitted.
- E.) A 2"-inch maximum air deflector in front of the radiator for engine cooling will be permitted.

15.7.7 Door Panels

- A.) The side door panel(s) will be a maximum of 86" inches and a minimum of 60"-inches in front of the centerline of the rear axle when measured along the top plane. The door(s), front door extensions and rear quarter panels must be flat and mounted in a vertical position. They must remain flat. **Flanges at a 90 degree angle may be added to the front of the doors. The flange may only be added for the purpose of strengthening the door material. The flange must not exceed ¾"-inch in length or width and must be mounted in a vertical position. Door flanges must face inward toward the centerline of the chassis.** Louvers, bead rolls holes and/or protrusions from top-to-bottom will not be permitted. Holes will be permitted for rub rails/nerf bars. A maximum 1"-inch long lip/flange at a 45 degree outward angle ½"-inch away from the sheet metal for reinforcement will be permitted at the top and bottom of the door(s) panels. All outside sheet metal, door panels, door extensions, air dams, front nose and/or hood fins must be the same shape, size and angle on both sides of the car. The door(s) must match each other from side-to-side (symmetrical). **Air directional devices and/or side mounted spoilers of any type, which extend past the outside edge of the flat plane of the body will not be permitted.**
- B.) Bead rolls around the outside perimeter of the door panels and the wing windows will be allowed. Bead rolled edges must face toward the center of the chassis.
- C.) The top of the door when measured from the ground will be a maximum of 38" and a minimum of 30"-inches when measured 60"-inches from the rear axle centerline. The rear of the door when measured from the ground will be a maximum of 42"-inches to the top of the door when measured 16"-inches from the center of the rear axle centerline of the rear forward.
- D.) The ground clearance on the bottom of the doors must maintain a maximum of 12"-inches and a minimum of 6"-inches from the ground.
- E.) A maximum lip and/or flange of 1-1/2"-inches rounded at 90 degrees and facing inward only, on the top and bottom door(s) and rear quarter panel(s) will be permitted.
- F.) A lip and/or flange angled out at a maximum angle of 45 degrees, extending away from the door at a maximum of ½"-inch and a maximum of 1"-inch in length before it bends inward for strength at the top of the door(s) and/or rear quarter panel(s) will be permitted.

15.7.8 Rear Quarter Panels

- A.) The rear quarter panels must be symmetrical in height, with or without plastic.
- B.) The rear quarter panels must be a maximum of 47"-inches and a minimum of 40"-inches from the ground at the rear and continue in a straight line with the top of the door. (See drawing.).
- C.) A maximum 2"-inch fender flare may be used, but the overall body width must maintain a maximum of 68"-inches.
- D.) The rear quarter panels may extend rearward a maximum of 48"-inches when measured along the top plane of the rear quarter panel and a minimum of 44"-inches at the bottom when measured from the center of the rear axle to the rear of the car.
- E.) A maximum of 16"-inches and a minimum of 8"-inches of ground clearance (when measured from the ground to the bottom of the rear quarter) will be permitted.
- F.) The plastic / rubber material utilized on the rear of the car may extend a maximum of 16"-inches from the ground to a minimum of 8"-inches from the ground on either side of the car (symmetrical).

- G.) The panels may have one side plastic on one (1) side only provided the panel remains completely symmetrical.
- H.) **Flanges at a 90 degree angle may be added to the Rear Quarter Panels. The flange may only be added for the purpose of strengthening the Rear Quarter Panel. The flange must not exceed ¾"-inch in length or width and must be mounted in a vertical position. Rear Quarter Panel flanges must face inward toward the centerline of the chassis. Air directional devices and/or side mounted spoilers of any type, which extend past the outside edge of the flat plane of the body will not be permitted.**

15.7.9 Rear Spoiler

- A.) A one piece, clear Lexan spoiler with a maximum height of 5"-inches from the rear deck will be permitted. Lettering and/or decals will not be permitted.
- B.) The rear spoiler must be non-adjustable from the cockpit and/or during racing conditions. Hinges, adjuster(s), slides and/or any other adjusting type device will not be permitted.
- C.) Metal gurney and/or table and/or flanges and/or lips will not be permitted.
- D.) A brake and/or bend on the top of the Lexan spoiler will be permitted for reinforcement. Maximum 1" lip.
- E.) The maximum overall height of the spoiler when measured from the ground must not exceed 50"-inches.
- F.) A maximum four (4) of vertical supports (a maximum of 2"-inches in vertical height and 10"-inches in length) for the purpose of fastening the spoiler to the rear deck will be permitted.

15.7.10 Rear Deck

- A.) The maximum height the rear deck when measured from the ground will be 47"-inches and a minimum of 40"-inches.
- B.) The rear deck lid must be fully enclosed from side-to-side and have a maximum height of 14"-inches and a minimum 9"-inches, vertically behind the fuel tank.
- C.) The left and right rear trunk lids must be symmetrical in size and shape and must remain flat to cover the fuel filler hose and apparatus. The panel must completely cover the fuel cell, the fuel filler hoses and the vent lines.
- D.) The fuel tank must be completely enclosed from the bottom of this panel to the bottom of the fuel cell.
- E.) The fuel cell must have both sides completely covered in sheet metal in addition the container it is enclosed in. Openings of any type will not be permitted.
- F.) Openings from the top of the fuel cell to the bottom of the trunk lid will not be permitted.
- G.) All vent line nozzles used for the purpose of a catch must be mounted on the left side of the quarter panel.
- H.) Crew members will not be permitted behind the car during a pit stop with refueling.

15.7.11 Hood, Nose and Front Spoiler

- A.) The maximum width for the hood, nose and front spoiler will be 36"-inches with a minimum width of 24"-inches. Louvers will be permitted on the sides of the hood. One per side.
- B.) The nose-piece must not extend rearward of the front shock towers.
- C.) The front spoiler must be a separate piece.
- D.) Shock absorber covers and/or deflectors must not be a part of the nose or the spoiler and/or positively fastened to the nose in any fashion exceeding the 36"-inch maximum width.
- E.) Fabric material shock absorber covers will be permitted. The covers must not be used to achieve any aerodynamic advantage and/or to deflect air in a positive manner.

- F.) The maximum the spoiler may extend in front of the front axle centerline will be 20"-inches.
- G.) The front spoiler must be non-adjustable (hinges and/or sliders will not be permitted).
- H.) The hood shall be considered from the front roll cage to on top and in-line with the front of the radiator.
- I.) The hood and nose may have a maximum lip and/or flange of 2"-inches on both side following the contour of the body. They must remain symmetrical.
- J.) The hood and nose be centered on the centerline of the frame.
- K.) The hood, nose and/or spoiler must not overlap each other's location on the frame.
- L.) Any part of the hood must not exceed 10 degrees and the sheet metal must not have an opening and/or extrusion between the hood and the nose.
- M.) The hood must extend over the radiator and have complete sides.
- N.) The front spoiler may have a lip and/or flange a maximum 2"-inches on both sides following the contour of the spoiler not exceeding the maximum width of 36"-inches. The front spoiler may be offset 1"-inch from the centerline of the frame to the right or the left. One 2" high wicker bill may be added horizontally to spoiler in front of shock towers.

15.7.12 Hood Scoop

- A.) The hood must be fully enclosed.
- B.) There are two (2) of hood scoops that can be mounted on top of the hood for the purpose of enclosing the carburetor and/or ram air. Ram Air will be permitted providing they meet the following specifications in this section.
- C.) The ram air scoop: A maximum 30"-inch length when measured from the rear motor plate to the front of the hood scoop will be permitted. A maximum width of 18"-inches will be permitted. The maximum 6"-inch front vertical opening at the beginning of the scoop will be permitted. A minimum of 8"-inches will be required from the highest point on the hood scoop to the lowest point on the front of the front of the roll cage and/or the roof. The hood scoop must be positively fastened to the hood and completely enclose the carburetor and the air filter.
- D.) The conventional air scoop (non-ram air): A maximum of 25"-inches is permitted from the center of the carburetor forward to the end of the hood scoop. A maximum width of 22"-inches will be permitted. A minimum of 8"-inches will be required from the highest point on the hood scoop to the lowest point on the front of the front of the roll cage and/or the roof. The hood scoop must be positively fastened to the hood and completely enclose the carburetor and the air filter.

15.7.13 Interior Sheet Metal

- A.) All horizontal body support(s) other than the inner pods, whether in the front and/or rear must be a minimum of 1" x 1" .095"-inch thick tubing or 1"-inch flat stock a minimum of .125"-inch thick..
- B.) Inside and/or outside wings, spoilers, air foils and/or wind deflectors will not be permitted.
- C.) Double panels and/or sheet metal that is designed to create a wing effect will not be permitted.
- D.) A maximum 1"-inch reinforced flange will be permitted on all lexan, however, all specified measurements must be retained.
- E.) All interior sheet metal must completely cover all interior areas, door-to-door, quarter panel-to-quarter panel. Holes and/or openings will not be permitted in this area.
- F.) Front and rear firewalls are required. The front firewall must isolate the cockpit from the engine compartment. The rear firewall must extend from the top of the fuel cell to the belly pan to isolate the cockpit from the fuel cell. The firewall must be a minimum of .050"-inch thick aluminum and/or magnetic steel. The firewall may be altered and/or cut for drive shaft clearance.

- G.) Vertical fins, air dams and/or fairings on either side, behind the roll cage will not be permitted.
- H.) All sheet metal must be a flat single plane across the interior of the car. Two (2) bead rolls or breaks for the purpose of strengthening and maintaining the shape of the wing will be permitted. The maximum bead roll and/or break permitted will be 1/8"-inch in height and 1/2"-inch in width.
- I.) Covered roll bars will not be permitted. Sheet metal that is one-piece and/or part of a body panel formed around tubing that is not considered an aerodynamic advantage will be permitted, provided there is no excess sheet metal.
- J.) Louvers will be permitted for cooling purposes only, including the radiator, engine and/or working oil cooler. Louvers and/or holes in the interior or exterior sheet metal will not be permitted.
- K.) The floor and/or belly-pan may not be any wider than the frame at any point. Lips, fins and/or air directional devices on the floor and/or belly pan will not be permitted. The under pan must not extend in length past the rear of the seat and exceed the width of the frame rails of the car and must be a maximum of .090"-inches in material thickness.
- L.) Only aluminum belly pans will be permitted. Panels under the rear and and/or the fuel tank will not be permitted.

15.7.14 Driver Compartment

- A.) A full metal firewall fabricated from magnetic steel and/or aluminum must encompass the driver's compartment from front-to-rear, on both sides and floor boards.
- B.) The driver's seat must be a high back aluminum seat, designed specifically for racing, located on the left side of the car and mounted per the manufacturer's instructions securely to the frame.
- C.) The seat design should be one from a current manufacturer and/or recommended to include the full containment design. Installation of the full containment seat should follow the manufacturer's instructions.
- D.) All cars must be equipped with a quick-release type steering wheel.
- E.) The driver compartment must have a starting switch and/or button within reach of the driver.
- F.) A clearly labeled electrical on/off 'kill' switch must be within reach of the driver.
- G.) Mirrors of any-type will not be permitted.
- H.) Radios and/or electronic and/or data communication devices will not be permitted.
- I.) Any edge and/or sheet metal end in and around the driver compartment must be protected with trim and/or beading and rounded. Sharp and protruding edges will not be permitted.
- J.) A substantial rock guard with a minimum of three (3) additional roll bars must be mounted in front of the driver. The rock guard must be made from wire screen. Windshield screens must be a minimum of .090-inches and must be securely fastened.
- K.) Fuel and/or power steering lines and/or fittings running through the driver's compartment must be made from an approved braided type of line. High pressure lines and/or fittings and/or hot fluid lines running through the driver's compartment must be encased and/or must have a shield.
- L.) A fully charged fire extinguisher meeting SFI 167.1 specifications with an activation push and/or pull knob within reach of the driver is recommended.
- M.) Shoulder guards will allowed on right side of drivers compartment but must be hinged on front edge and attached with Velcro on back edge as to not be mounted solidly.

15.7.15 Numbers and Identification

- A.) The track and/or series Scoring Director reserves the right to issue and/or change a car number to prevent duplication and/or maintain proper records.
- B.) Team cars must be clearly identifiable from one another and use another number and/or letter.
- C.) All number and letter combinations will be limited to three digits. If three digits are used two (2) shall be the primary numbers/letter.
- D.) Number and/or letter combinations are required on the roof, nose, rear deck and both doors.
- E.) All numbers and letters must be a minimum of 18"-inches high on the roof and/or doors and 8"-inches high for the rear deck and the nose. All numbers and/or letters must be equal in size and displayed legibly whether decal and/or painted.
- F.) **For all Super DIRTcar Big Block Modified Series events, Big Block Modifieds must display a red and yellow (outline and/or fill) roof number with the letters "B.B." placed within the number to signify that the vehicle is a Big Block.**
- G.) **For all Mr. DIRTcar 358 Modified Series events, 358 Modifieds must display a blue and yellow (outline and/or fill) roof number with the numbers "358" placed within the number to signify that the vehicle is a 358 Modified.**
- H.) The nerf bars must not block the visibility of the number and/or letter combinations.
- I.) The letters of the driver's last name must be a minimum of 6"-inches in height and be positioned under, through and/or above number on both sides of the car.

15.7.16 Bumpers and Side Bars/Nerf Bars

General

- A.) All bumpers, side bars/nerf bars and/or bracing must be made from minimum 1-1/2 diameter round .095--inch thick magnetic steel tubing only unless otherwise specified.
- B.) All edges and/or corners on bumpers and side bars/nerf bars must be rounded. Sharp edges will not be permitted.
- C.) The rear bumper and/or any side bars must not extend past the outside of the tire sidewalls on either the left and/or right side of the car.

Front Bumper

- A.) Only the front bumpers may be made from minimum 1-1/4 diameter round .095--inch thick magnetic steel tubing.
- B.) The front bumper must consist of two (2) horizontal rails; an upper and a lower and a minimum of two (2) vertical braces, equally spaced, welded between the two (2) horizontal rails. The horizontal rails must be positively fastened to the frame with four (4) sockets and/or supports. **The front bumper must remain exposed without covering and/or any sheet metal fabrication surrounding it.**
- C.) The four (4) tubes that support the bumper from the four (4) frame sockets must be horizontal. These rails must be a minimum of 6"-inches and a maximum of 12"-inches apart when measured from the top to the bottom and maintain that measurement for a minimum width of 24"-inches and a maximum width of 30"-inches. The front bumper must also have an 18"-inch center when measured from the ground up to the middle of the bumper. **The total width of the front bumper must not exceed 30"**.
- D.) The maximum the front bumper may extend from the centerline of the front axle is 24"-inches and a minimum of 20"-inches.
- E.) The front surface of the bumper must remain flat, parallel and perpendicular with the front of the nose piece for the full width of the bumper. V-shaped and/or any other type of shaped bumpers will not be permitted.
- F.) The end bracing tube of the front bumper must be fabricated on an angle in such a way as to prevent the bumper of another car becoming interlocked. Please refer to the drawing at the back of this rule book.

Rear Bumper

- A.) The rear bumper must consist of two (2) rails, an upper and lower, which must have four (4) sockets and horizontal support bars positively attaching it to the frame. The upper and lower rails must also be a minimum of 10"-inches apart and a maximum of 16"-inches apart from the top to the bottom and maintain that measurement for a minimum width of the 64"-inches and a maximum of 86"-inches.
- B.) The rear bumper must have an 18"-inch center when measured from the ground to the middle of the bumper.
- C.) The maximum the rear bumper may extend back when measured from the centerline of the rear axle is 52"-inches.
- D.) The rear surface of the bumper must remain flat and parallel with the back of the rear quarter panel for the full width of the bumper. V-shaped and/or any other type of shaped bumpers will not be permitted.

Rub Rails

- A.) Solid rub rails and inner hoops with ballast added inside or outside will not be permitted.
- B.) The rub rails must be exposed and outside the body panels. The left side rub rail may extend a maximum of 2"-inches outside the left rear tire sidewall.
- C.) The rub rails must be bent with a gentle radius at a 90 degree angle and must protrude a minimum of 6"-inches back in past the body.
- D.) The rub rails must be a minimum of 50"-inches long from socket-to-socket

Bumpers and Rub Rails

- A.) Only a minimum of 5/16" bolts with Nyloc nuts and/or DIRTcar approved quick release solid pins will be permitted for positively fastening bumpers and rub rails to the car. Cotter pins and/or other fastening devices will not be permitted. **Effective immediately double rub rails will be allowed on Modifieds, 358 and Sportsman on left side only. Big Block and 358 Modifieds will be allowed right side rub rails until July 1, 2016.**
- B.) All bumpers and rub rail sockets must have fasteners, pins and/or bolts with a minimum diameter of 5/16"-inch.
- C.) The front and rear rub rails must have a 360 degree sleeve a minimum of 3/8"-inch wide x .095" thick magnetic steel welded to the rub rail tube butted against the support socket to prevent pins from shearing. Refer to the drawing at the back of this rule book.

15.8 Suspension

15.8.1 Front End

- A.) The front axle must be a straight, one-piece axle manufactured from magnetic steel tubing. Only approved camber adjustments and/or camber adjustment devices will be permitted. Any other camber adjustments and/or will not be permitted.
- B.) Split axles and/or dropped axles and/or independent front suspension(s) will not be permitted.
- C.) All brackets on the front axle must be welded and/or bolted. Bird cages and/or sliders will not be permitted.
- D.) Only Modified front spindles will be permitted.
- E.) Bearing shafts that are made of steel are recommended.
- F.) The chassis may be offset a maximum of 4"-inches from the center of the inside tire width measured from the inside of the left front tire to the inside of the right front tire at axle height. Refer to the drawing in the back of this rule book regarding front and rear end offset details.
- G.) The front wheels and tires must remain fully exposed. Fenders and/or air deflection devices of any type will not be permitted.

15.8.2 Shock Absorbers

- A.) Only one (1) shock per wheel will be permitted.
- B.) Externally adjustable shock absorbers will not be permitted. Shock absorbers with Schrader valves will be permitted.
- C.) External reservoir type shock absorbers will not be permitted.
- D.) All shock absorbers must be an 'in-stock' item with manufacturers. Custom shock absorbers and/or shock absorber components will not be permitted.
- E.) Prior to introduction into competition a new design shock absorber must be submitted to World Racing Group / World of Outlaws Officials for approval. Shock absorber manufacturers may be required to provide a board of components for inspection and display.
- F.) All Shock absorbers must be constructed of magnetic steel and/or aluminum.
- G.) Only conventional type closed shock absorbers and/or approved shock absorbers will be permitted for competition. Only single shaft shock absorbers will be permitted and all shock absorbers must remain closed on one (1) end via conventional design.
- H.) Electronically controlled shock adjustments by any means or method are not permitted.
- I.) "Through-rod" designs are not permitted.
- J.) Communication; hydraulically, electronically, magnetically, or otherwise, between any two or more shocks on a vehicle is strictly prohibited. This includes "cross-over" shocks.
- K.) Inerter style dampers, either mechanical or hydraulic, or other type of primarily acceleration sensitive damping device is not permitted

15.8.3 Suspension Components

- A.) Independent front and/or rear suspensions will not be permitted.
- B.) A-Frames and/or ball joints will not be permitted for steering axis (kingpin only).
- C.) Four-wheel steering actuated by the steering wheel and/or of any type will not be permitted.
- D.) All suspension systems and designs must be mechanical. Hydraulic, pneumatic (air), electronic, radio and/or computer assisted for adjustments and/or in-or-out of cockpit type suspensions and/or suspension adjustment systems will not be permitted.
- E.) Traction control of any type, including within the braking system is not permitted.
- F.) Only a single brake bias and single rear panhard adjustment will be permitted in the cockpit. Any other type of adjustment will not be permitted in the cockpit.
- G.) **Spring rods allowed on right rear radius rod only. Must be a conventional approved spring rod. No externally mounted shocks attached to radius rod.**

15.8.4 Springs

- A.) Any type and/or form of spring will be permitted (torsion bar, coil and/or leaf spring).
- B.) Carbon fiber and/or titanium springs will not be permitted.

15.8.5 Brakes

- A.) All cars must have four (4) wheel hydraulic brakes in good working condition. Random brake inspection may take place throughout the season.
- B.) Carbon fiber, carbon, titanium, ceramic, aluminum pads and/or rotors will not be permitted.
- C.) On live rear axles, one inboard and one outboard brake assembly will be permitted.
- D.) Brake bias may be adjustable through the cockpit.
- E.) Manual brake shut offs will not be permitted, with the exception of the right front brake. An electronic brake shut off switch will also be allowed on the right front only.

15.8.6 Wheelbase and Tread Width

- A.) The minimum wheel base is 106"-inches and a maximum of 110"-inches with a maximum tolerance of ½", when measured from the centerline of the rear axle to the centerline of the front axle for both left and right sides.
- B.) The maximum front tread width will be 86"-inches with a minimum of 74"-inches. The maximum rear tread width will be 86"-inches with a minimum of 80"-inches. These measurements will be taken from the outside edge of the sidewall of the tires on each side.

15.9 Roll Cage

- A.) Only round magnetic steel tubing 1-1/2" and/or 1-3/4" in outside diameter with a material thickness of 1-3/4"-.095"-inches and/or 1-1/2"-.120"-inches will be permitted.
- B.) The roll cage must be an integral and structural part of the frame. All frames built in 2005 and after must have a manufacturer's unique serial number plate visible and positively fastened on the left front roll cage upright. The letters and/or numbers shall not exceed 8 digits and be ½"-inch in height. See drawing 4.7.2
- C.) Front and rear roll bars must be positively fastened in a cage-type configuration. Two (2) round horizontal side bars on each side are required. The top side bar must be a maximum of 22"-inches below the top roll bar.
- D.) Proper bracing and triangulation on the front and rear roll bars is required. All roll bar bracing material must be 1-1/2"-inches outside diameter with a material wall thickness of .095"-inches. A minimum of one (1) 1" diagonal bar across the top of the roll cage is required.
- E.) The rear main roll bar hoop must be a minimum of 26"-inches when measured across the outside-to-outside of the hoop and maintain that measurement from the top to the bottom of the cage. The bottom of the rear main roll bar hoop must be positively fastened (welded) to the 2"x4" frame rails. Outriggers will not be permitted.
- F.) The front roll bar hoop must be a minimum of 26"-inches when measured across the outside-to-outside of the hoop and maintain that measurement from the top to the bottom of the cage, with the exception of the allowable frame taper. Outriggers will not be permitted. Refer to the drawing in the back of this rule book.
- G.) **MANDATORY Frame/Roll Cage update: A piece of tubing, a minimum of 1-1/4" in outside diameter and .095"-inches in thickness, must be installed vertically and must extend through the car into the bottom frame rail or extend back to the union at the top of the door and rear main hoop joint. The tubing must be installed in a manner that does not impede the driver exiting the cockpit. The tubing must be mounted a minimum of 9"-inches and a maximum of 12"-inches on the roof bar from the existing rear roll cage hoop. This must be installed symmetrically on both sides of the roll cage. Existing cars must be retrofitted with this piece of tubing.**

15.10 Wheels

- A.) Only aluminum wheels will be permitted for competition. Magnesium, steel, carbon fiber and/or any other exotic type material will not be permitted.
- B.) 'Bleed-off' and/or 'Bleeder' valves will be not be permitted.
- C.) The maximum rim width will be 14"-inches when measured from the inside of left bead to the inside of the right bead of the wheel. Only wheels 15"-inches in diameter will be permitted.
- D.) Beadlocks will be permitted. Any wheel utilizing a beadlock must maintain a minimum diameter hole of 11" or 5" inches inside the beadlock and the wheel. Beadlocks may only be used on the outside of the wheel.
- E.) Wheel covers and/or hubcaps will not be permitted on the inside of the wheel(s). Wheel covers and/or hub caps will be permitted on the outside of the wheel providing they are one piece, **bolted in 3 places to the wheel and/or beadlock** and that they maintain a minimum thickness of .090" with a minimum 1" diameter hole in the center of the cover.
- F.) **Effective with the first 2016 event only steel wheel cover fasteners will be allowed.**

- G.) **It is highly recommended that wheel covers have a minimum of 5 mounting points.**
- H.) Foam inserts may be permitted. If wheel covers are not properly installed, they may not be permitted.
- I.) A minimum of five (5) lug nuts on the rear wheels will be required. A minimum of three (3) lug nuts will be required on the front wheels. Knock off hubs of any type on any wheel will not be permitted.

15.11 Tires

- A.) Individual race tracks, events and/or series may designate a particular tire and/or compound at any time. The compound may be announced prior to the event in a bulletin and/or at the driver's meeting.
- B.) Only Hoosier Racing Tires will be permitted in any DIRTcar sanctioned events. Hoosier (the tire manufacturer) will mark/stamp/brand all legal tires with specified compound and/or other specific DIRTcar designations as listed below;

Big Block and 358 Modifieds:

- 1.) D300 ("DIRT Soft")
- 2.) D400 ("DIRT Hard")
- 3.) D500 ("DIRT X-Tra Hard")

Tire Size and Compound Designation:

- Front - 11/82-15
- Front - 13/82-15
- Rear - 13/87-15
- Rear - 13/89 - 15
- Rear - 13/92-15

- C.) The minimum rear tire pressure will be as follows; Left rear a minimum of 7lbs. The right rear will be a minimum of 10 lbs.
- D.) The altering of any tire compound, by any means will not be permitted. Chemical alteration of the tread carcass and/or tread compound, such as tire 'soaking' and or the introduction of tread 'softener' and/or the physical defacement (removal, altering and/or covering) of tire sidewall markings in any manner will not be permitted. If any competitor is found to have altered their tires any penalty deemed appropriate by Super DIRTcar Series and/or DIRTcar Officials may be issued. Tires may be protested by another competitor following the protest rules as stated in section 11.2.
- E.) Any tire may be inspected and/or analyzed for alteration at any time. This will consist of a process as determined by the independent laboratory that performs the analysis. A "Chain of Custody" process will be outlined with the competitor upon inspection of the tires.
- F.) The analysis process will require shipment of the tire to the selected laboratory. Additional race event(s) may be completed before a determination is made. If a penalty is issued, the event(s) that fell into the analysis time period while the tire(s) were being analyzed may be considered as part of the penalty time period.
- G.) Reference Section 5.3.D. for Competitive Analysis, Section 11.1.1 for Penalties and/or Section 11.2.1 for Protest(s).
- H.) Removable duct tape, provided it does not deface the tire, to cover the D-Number will be permitted.
- I.) Heating of the tires by torch, blanket, heating device(s), exhaust system and/or any other method will not be permitted.
- J.) Inner liners of any type will not be permitted.
- K.) A tire durometer may be used during the tire inspection process, provided baseline tire(s) have been read at the event prior to inspection.

15.12 Personal Safety Equipment – see section 3.0

15.13 Other

- A.) Cars will not be permitted to make a qualifying attempt without passing technical inspection. All cars must be available for inspection prior to the time of the driver's meeting. Following the driver's meeting, covers of any-type on the racecar will not be permitted.
- B.) All fuel lines, power steering lines and/or fittings running through the driver's compartment must be made from a braided or other approved type line. Plastic and/or glass fuel filters will not be permitted.
- C.) All cars may be subject to technical inspection at any time.
- D.) Full or partial car covers will be permitted only when there is inclement weather and/or the car is in its designated pit stall. All covers shall be removed prior to the car leaving its designated pit stall.
- E.) SFI-approved and labeled containment seat recommended. Roll bar padding mandatory on all roll bars that helmet may come in contact with. Knee and steering pads and/or padding is recommended.
- F.) All teams must have a fire extinguisher in the rear of their transporter with the car number clearly visible on the extinguisher. The fire extinguisher must be a minimum of 20lbs and is recommended to FFF type chemical and/or DuPont FE-36 and/or equivalent.
- G.) All drivers are required to have a one-way radio. The one-way radio must be working and active prior to any 'on-track' activity. Two-way radios, crew-member to driver and/or any other means of electronic communication, other than the one-way radio will not be permitted.
- H.) Seven (7) days prior to any scheduled and/or sanctioned one (1) day DIRTcar Northeast Series event paying less than \$20,000-to-win race teams will not be permitted to rent, test and or attend any practice session(s) at the scheduled track, unless approved by DIRTcar. Any race team and/or driver in violation will be given one (1) lap of qualifying and the best the qualifying position that will be earned is 50% + 1 of the entered cars for that event.

15.14 Series Decal and Patches

- A.) All participants will be required to display decals as provided on the decal verification sheet prior to entering into competition. If any required decal is not displayed loss of any awarded money will be the penalty.
- B.) A series decal is required on both sides of the car. Driver must display the series patch on their uniform to receive point fund awards.
- C.) Contingency and sponsorship awards, any team participating must meet the requirements of the award(s) such as decals, patches, product use and verification. There will be a written deadline presented to the teams prior to the start of each season for each element to be in place for the award requirements. If it is an existing program it will roll over from the prior season and the program will begin at the first race of the season.

15.0-B DIRTcar 358 Modifieds

ANY CAR, TEAM AND/OR DRIVER THAT DOES NOT MEET THESE SPECIFICATIONS AND/OR EQUIPMENT REQUIREMENTS WILL BE SUBJECT TO PENALTIES AS DETERMINED BY THE Super DIRTcar and/or DIRTcar and/or World Racing Group OFFICIALS.

Note; Unless otherwise noted within Section 15.0-B, the rules remain the same as presented in section 15.0-A.

15.1 Engines General and Location

A.) Conventional stock type V-8 engines (OEM American with cast iron blocks and Brodix Aluminum Cylinder Heads. Ported OEM and/or the DART Iron Eagle Cylinder Heads will be permitted. Aluminum engine blocks will not be permitted. The following are the approved cast iron engine blocks permitted for competition.

- a. OEM Chevrolet and Bow Tie Performance
- b. OEM Chrysler and R Performance
- c. OEM Ford and SVO Performance
- d. DART Performance (Little M)
- e. DART Rocket Block 31121111
- f. DART SHP Block 31161111 4"-inch bore

B.) ALL engines must maintain stock bore and stroke combinations.

- a. Engine Maximum Overbore Cubic Inches (C.I.):
- b. Chevrolet 350 C.I. 4,00" bore x 3.480" stroke + .070 maximum over bore = 363
- c. Chrysler 360 C.I. 4,00" bore x 3.578" stroke + .020 maximum over bore = 364
- d. Chrysler 340 C.I. 4,04" bore x 3.313" stroke + .060 maximum over bore = 350
- e. Ford 351 C.I. 4.00" bore x 3.500" stroke +.060 maximum over bore = 363

C.) Reverse rotation engines will not be permitted.

D.) The engine must be centered in the front of the chassis and placed in an upright position.

E.) Engine set back will be as follows; Minimum is 56"-inches and a Maximum of 66"-inches with a tolerance of ½"-inch (+/-). The setback will be measured from the centerline of the front axle to the rear machined surface **where the motor plate attaches the motor.**

F.) Engines must not pump more than the specified cubic inch.

G.) Only normally aspirated engines will be permitted.

15.1.1 ENGINE BLOCKS

A.) Only stock OEM and cast iron performance blocks including the Chrysler (R) Block, Chevrolet Bow-Tie, Ford-SVO and/or DART Blocks will be permitted. Aluminum blocks will not be permitted.

B.) Lightening and/or machining of engine blocks will not be permitted. The engine block must remain as received from the manufacturer. Any alteration will not be permitted.

15.1.2 Cylinder Heads and Intake Manifolds (358 Modified Engine Combinations Specifications)

A.) There will be three (3) cylinder head assemblies permitted;

Option –A

(2,400 lbs – Spec. Heads, Intake and Exhaust)

1. Brodix 'Spec' Aluminum Head Option; One (1) degree angle mill will be permitted. The cylinder head must remain as manufactured by the manufacturer. Only the specified intake manifold part numbers will be permitted. Oil lines and/or brackets must not be mounted in front of the cylinder heads for ease of inspection and measuring the dowel pin holes. Matching and/or porting of the cylinder heads will not be permitted. The cylinder heads and intake manifold must remain as manufactured by the manufacturer. A magnetic steel or aluminum oil pan will be permitted.

2. The maximum compression ratio on any aluminum cylinder head package will be 10.5:1.
3. All Brodix 'Spec' Cylinder Heads will be supplied with CNC bowl blend and CNC combustion chamber and intake port matching.
4. Grinding and/or blending or CNC work will not be permitted.
5. Grinding and/or polishing anywhere on the cylinder head casting will not be permitted.
6. The use of substances that may change and/or alter the shape, finish and/or size of the ports and/or combustion chamber will not be permitted.
7. The maximum intake valve size of 2.080"-inches and a maximum exhaust valve size of 1.600"-inches will be permitted for all Brodix 'Spec' Cylinder Heads.
8. Titanium valves, titanium valve train components will not be permitted. Titanium retainers and/or keepers will be permitted.
9. Alterations to the valve seats and/or valve guides will not be permitted. The valve seats and/or valve guides must remain as manufactured in their cast positions.
10. Valve stem angles must remain as manufactured. The original valve seat center location(s) as provided by the cylinder head manufacturer (Brodix) must not be altered. Any valve repair job will only be permitted on steel seat concentric to the guide. Justifiable and reasonable enlargement of the valve seat concentric to the valve guide as the result of a valve repair job will be permitted, but the combustion chamber must retain the stock OEM dimensions as cast by the 'Spec' head manufacturer (Brodix).
11. Tapering and/or reshaping of the valve guide(s) will not be permitted.
12. Only 11/32"-inch diameter valve stems will be permitted. Neck down type valves will be permitted.
13. Brodix 'Spec' Cylinder Head serial/ part, ID, markings and/or numbers must remain unaltered. Defacing and/or altering of the part identification information will not be permitted.
14. Brodix, as the 'Spec' Cylinder Head manufacturer may repair cylinder heads with authorization from DIRTcar, Super DIRTcar Series and/or World Racing Group Officials.

Option B-
(2,500 lbs Brodix Cylinder Heads)

- 1) As referenced in 15.1.3 and 15.1.4

Option -C
(Ported Cylinder Heads) For 2013:

- 1) Cast-iron heads; Chevrolet Bow-Tie, Chrysler W2, Ford performance cylinder heads, OEM and/or DART Iron Eagle 200, 215 or 230. Welding or the addition and/or shaping of epoxy will not be permitted. Porting on cylinder heads and/or intake manifold will be permitted. Any American manufactured cast aluminum single plane one piece construction intake manifold will be permitted. Porting will be permitted as an option on the intake manifold. Oil pan and exhaust are optional. The minimum overall weight for this engine combination will be 2,650 lbs.
- 2) All part numbers must be approved by DIRTcar.
- 3) Casting and/or part numbers may not be altered and/or removed.
- 4) Cylinder heads must retain OEM port centers, spark plug location and all stock OEM angles and may be ported.

B.) Any deliberate 'Spec' Cylinder Head rules infraction may result in a suspension from all DIRTcar sanctioned tracks. In post-race inspection DIRTcar has the option of removing cylinder heads for inspection purposes. Failure to cooperate in removing cylinder heads for the purpose of inspection will result in an immediate disqualification from the event and may result in additional penalties as set forth by DIRTcar and/or Super DIRTcar Series Officials.

C.) DIRTcar and/or Super DIRTcar Series officials reserve the right to exchange and/or 'swap' cylinder heads with a race team at any time. Failure to cooperate in exchanging and/or swapping cylinder heads for the purpose of inspection will result in an immediate disqualification from the event and may result in additional penalties as set forth by DIRTcar and/or Super DIRTcar Series Officials.

15.1.3 Intake Manifold (General)

A.) Any single piece American production cast aluminum single plane manifold that permits the mounting of one (1) four barrel carburetor will be permitted. Multiple piece intake manifolds will not be permitted. The intake manifold must remain unaltered. Matching, welding, the additional of material and/or epoxy will not be permitted.

B.) Casting and/or part numbers must remain visible and must not be altered in any manner.

C.) The intake manifold may be ported. If the intake manifold is ported and utilizes the Spec. Brodix cylinder heads the car must compete at the 2,500 lb overall weight. If the engine utilizes Cast Iron Cylinder Heads, the car must compete at the 2,650 lbs overall weight. The addition of any material to the intake manifold will not be permitted.

D.) The following are the approved intake manifolds;

- a. Chevrolet 350 C.I. Brodix Part # HV1000
- b. Chrysler 360 C.I. and 340 C.I. Edelbrock Part # 2915
- c. -Chrysler 360 C.I. and 340 C.I. Stanton part # P4532966SR
- d. Ford 351 C.I. Edelbrock Part # 2981 9.5"-inch deck height
- e. Ford 351 C.I. Edelbrock Part #2980 9.2"-inch deck height

15.1.4 Exhaust - Muffler and Sound Reduction Devices

A.) The following are the approved Schoenfeld and Beyea headers allowed to compete at the 2,400 lb weight:

- a. Chevrolet – 1-3/4" to 1-7/8" Schoenfeld Part # 1124 BV
- b. Chevrolet – 1-5/8" to 1-3/4" Schoenfeld Part # 1122 BV SH – 3
- c. Chrysler – 1-3/4" to 1-7/8" Schoenfeld Part # 4124 BV SH
- d. Chrysler – 1-5/8" to 1-3/4" Schoenfeld Part # 4122 BV SH – 3
- e. Ford – 1-3/4" to 1-7/8" Schoenfeld Part # 3124 BVN
- f. Ford – 1-5/8" to 1-3/4" Schoenfeld Part # 3122 BVN – 3
- g. Chevrolet – 1-5/8" to 1-3/4" Beyea Part # NEDMSB36-S2-3

B.) Only magnetic steel exhaust headers will be permitted. The four (4) primary pipes going into one collector. Stainless steel, iron lung, tri-y type, merge collectors and/or any other type exhaust design will not be permitted. Ceramic coating and/or any other type coatings will not be permitted.

C.) All 2,400 approved Headers must be able to be separated from the rest of the exhaust system for the purpose of inspection.

D.) The complete exhaust system must be sealed. Any type of add on, return system and/or exhaust evacuation system will not be permitted. All cars competing at the 2,500 lb weight may run headers as referred to in the Super DIRTcar Series Big Block Modified section 15.3-A Exhaust – Muffler and Sound Reduction Devices.

15.1.5 Carburetor

A.) Only one (1) 650 cfm Holley carburetor, Part Number 4777 or 80777 or Holley HP Carburetor Part Number 80541-1 will be permitted.

B.) 4777 and 80777 Option:

- 1) The carburetor must maintain the stock venture and throttle bore dimensions; the primary venture 1-1/4" and the secondary venture will be 1-5/16".

- 2) The carburetor must maintain all stock dimensions, including mounting and stud location on intake manifold.
 - 3) The booster height must remain stock OEM from Holley. Cutting, tumbling and/or polishing will not be permitted.
 - 4) Visible modifications will not be permitted.
 - 5) The maximum height of the carburetor when measured from the bottom of the carburetor and/or the throttle plate to the machined horizontal surface of block will be in 7"-inches in both the front and rear of the block. Any carburetor spacer may be used to maintain the height with nothing going below the top of the machine surfaced of the intake manifold. Turtles, air dams and/or any type of similar device will not be permitted.
 - 6) The following alterations will be permitted;
 - i. Holes drilled in the throttle plate for proper idle.
 - ii. Drilling, tapping and plugging of unused vacuum ports.
 - iii. Welding of throttle shaft to linkage arm.
 - iv. Drilling of idle and/or high speed air correction jets.
 - v. Milling of center carburetor body metering block surface, maximum of .015" on each side.
 - vi. Removal of choke plate and shaft.
 - vii. The jets may be changed as needed.
 - viii. Gauge measurements (go/no-go) must be met at all times, regardless of carburetor temperature.
- C.) HP 80541-1 Option:
1. The carburetor must remain stock retaining all Holley measurements and dimensions. The carburetor may be adjusted utilizing only specified Holley replacement parts.
 2. Jets, bleeds, needle and seat, emulsion bleeds, power valves, accelerator pumps nozzles and accelerator pump cam adjustments will be permitted.
 3. Physical alteration of carburetor components and/or parts and/or any alterations, machining and/or reshaping will not be permitted. The use of epoxy and/or coatings of any kind will not be permitted.
- D.) **A shield may be used under the air filter base and must remain on top of the carburetor main body (venturi opening) in an attempt to seal off the air cleaner area. Any type of shield that covers the engine compartment area will not be permitted. A shield may be attached to the hood or air filter base plate for the purpose preventing dust and/or exterior elements being introduced into the air breather. Any shields new in design must be submitted to DIRTcar for approval.**

15.1.7 Camshaft

- A.) The camshaft must maintain stock location and position in engine block. Design and/or manufacturer may vary.
- B.) Gear and/or belt drives will not be permitted.
- C.) Overhead cams will not be permitted.
- D.) Roller and/or shaft rockers will be permitted.
- E.) Stud girdles will be permitted.
- F.) Lifters must retain stock diameters, angles and positions. Re-bushing for wear will be permitted.

15.1.8 Pistons, Connecting Rods, Crankshaft and Vibration Dampeners

- A.) Any steel and/or cast iron crank shaft maintaining stock stroke dimensions for the engine block that is used will be permitted.
- B.) OEM stock production and/or aftermarket magnetic, solid steel rods with a maximum length of 6"-inches will be permitted.
- C.) Titanium and/or aluminum rods will not be permitted.

- D.) Only 3-ring, flat top aluminum pistons will be permitted.
- E.) Engines with connecting rods longer than 6"-inches must maintain stock OEM specifications and measurements.
- F.) Only one (1) magnetic steel or cast iron stock OEM and/or aftermarket dampener (balancer) will be permitted
- G.) Only one-piece constructed dampeners, fluid and/or friction dampeners meeting the SFI 18.1 specifications will be permitted for competition.
- H.) Bolt and/or snap-ring assemblies will not be permitted.
- I.) Safety snap rings will be permitted
- J.) Rubber-lined dampeners will be permitted.

15.1.9 Ignition

- A.) Only DIRTcar approved MSD Box Part #64316-MSD/DIRT 6ALN fixed 7600 will be permitted for both ported and Brodix 'Spec' Cylinder head engine options. The ignition box must remain unaltered. Only one (1) approved MSD Box will be permitted per car. The ignition box must be in operating and working condition before, during and after the racing event.
- B.) **The ignition amplifier box ("rev box") and coil must be mounted under the hood (out of the driver's reach) and must be clearly visible for ease of inspection.**
Mounting under the hood includes behind the instrument gauge cover at the rear of the hood area. All wires from the ignition amplifier box must have a clear and direct path to their connections. The shortening of wires will be permitted to accomplish this. Bare wires and/or exposed wiring and/or tape(d) and/or wire looms of any type will not be permitted.
- C.) Ignition boxes must remain as manufactured. Internal and/or external alterations and/or modifications will not be permitted. Crank trigger systems of any type will not be permitted.
- D.) The ignition must be mechanically driven in the stock OEM location.
- E.) Only one ignition coil will be permitted on the car.
- F.) The wiring must remain as specified by the ignition amplifier box manufacturer.
- G.) One American Passenger Car sized battery with terminals on top and a maximum of 12 volts will be permitted. The battery voltage must not measure more than 14.3 volts. Step up transformer and/or any other device designed to increase voltage will not be permitted.
- H.) OEM stock firing order must be maintained for all engines.
- I.) Ignition amplifier boxes may be confiscated and/or exchanged at any time.

15.1.10 Lubrication/Oiling System/Oil Cooler

- A.) Only a single wet sump oil pump will be permitted. Dry sump oil systems will not be permitted.
- B.) **The oil pan may be magnetic steel or aluminum. The oil pan must have a 1"-inch diameter inspection hole for inspection of connecting rods. The hole must be in the left side of the oil pan. If the inspection hole is not present, removal of the oil pan will be required for inspection.**
- C.) External type oil pumps and/or vacuum pumps will not be permitted.
- D.) Accu Sumps will be permitted.
- E.) Oil coolers will be permitted. Please refer to section 15.1.7-A (Big Block section) for mounting location and other rules specific to the oil cooler.
- F.) Oiling evacuation (EVAC) systems from the valve covers to the exhaust system will be permitted. No air pumps allowed.

15.2 Fuel, Fuel Cells and Fuel System

- A.) Fuel coolers of any type will not be permitted.
- B.) **Only 'D'-type VP Racing Gasoline, the official fuel of DIRTcar will be permitted for competition. VP D-113, D-12, and D-109 will be the only specified fuel permitted at any sanctioned DIRTcar and/or Super DIRTcar Series event. Blending of fuels, including VP spec (including 'D') fuels of different octane will not be permitted. Alcohol, methanol, nitrous oxide, nitro-methane and/or propylene oxide will not be permitted. Fuel may be subject to inspection and testing at any time. Proof of purchase for the official fuel of DIRTcar may be required.**

15.3 Weight / Ballast

- A.) All 358 DIRTcar Modifieds utilizing a DIRTcar 358 Modified engine with the Brodix "Spec" heads, ported intake and "tri-y" exhaust must maintain a minimum weight of **2,500** lbs following the completion of any event.
- B.) All 358 DIRTcar Modifieds utilizing a Brodix "Spec." DIRTcar 358 Modified engine with the stock intake manifold (reference 15.3.A.; 15.1.3; 15.1.2 A.) and spec. Schoenfeld headers and a steel or aluminum oil pan must maintain a minimum weight of **2,400** lbs following the completion of any event.
- C.) **All 358 DIRTcar Modifieds utilizing the optional Chevrolet Performance 525 Crate Engine must maintain a minimum weight of 2,450 lbs following the completion of any event.**
- D.) All 358 DIRTcar Modifieds utilizing a ported steel head DIRTcar 358 engine per this rule book must maintain a minimum weight of 2,650 lbs following the completion of any event.

15.4 Optional Chevrolet Performance CT 525 Engine

- A.) The General Motors (GM) Engine part number #197271821 CT525 will be permitted as an optional engine for use within the DIRTcar 358 Modified division. The engine will not be permitted in any sanctioned series event and/or for use at any DIRTcar sanctioned facility that does not permit the engine for competition.
- B.) It is the right of any DIRTcar sanctioned facility to apply these rules as an option for the Optional Chevrolet Performance CT 525 Engine for use in a division, which utilizes only the General Motors (GM) Engine part number #197271821 CT 525 in conjunction with the rules as stated within the rules and section 15.0-B DIRTcar 358 Modifieds.
- C.) The engine and all components must remain in their original configuration and form as purchased and/or delivered from the factory. Any alterations to the engine will not be permitted. The Engine must remain as manufactured by General Motors. Overbore(s) will not be permitted. Repairs may be permitted with written permission from DIRTcar and/or World Racing Group Officials.
- D.) All engines are to remain sealed from the factory. The original factory seals must remain unaltered, tampering, removal, modifications of any type and/or broken factory seals will not be permitted. The GM Engine must remain unaltered in any way.
- E.) The GM Crate Engine seals (bolt-type) must remain unaltered. DIRTcar and/or World Racing Group Officials may require specific sealing and verification of all seals on any GM Crate Engine. Tampering with and/or alteration of any seals will not be permitted and is subject to immediate penalty and/or suspension.
- F.) Only GM replacement parts of any type will be permitted for any type of replacement and/or repair work. Only GM Crate Engine specific valve springs may be used for replacement and/or repair,
- G.) The maximum RPM of the GM CT 525 engine will be 7,500 as controlled by the Chevrolet Performance Parts 'Crank Trigger Control' as purchased from the manufacturer.
- H.) All other DIRTcar 358 Modified Engine rules apply, with the exception of the header rule(s). The recommended exhaust headers will be the Schoenfeld 1124bls1-3 or the Beyea DM-525.
- I.) GM Crate Engine repairs must be authorized by DIRTcar. GM Crate Engine repair procedure works as follows:

- a. Contact your track promoter and/or your local track and/or DIRTcar Technical Officials.
 - b. The Promoter and/or Technical Officials will specify a repair location and instruct the driver/owner where to take the engine to get an estimate.
 - c. Based on the estimate and the detail of the repair, DIRTcar and/or World Racing Group officials will determine if the repairs may be made or if a new engine must be purchased.
 - d. If a repair is approved, a specified inspector will inspect the engine and work with the engine repair facility throughout the duration of the repair to ensure that the engine maintains the GM Specifications.
 - e. Upon completion of the repair(s) the engine will be 'resealed' before being released for competition.
 - f. All parts including the gasket repair kit(s) must be stock OEM Chevrolet Performance replacement parts. The receipt(s) generated from the Chevrolet Performance Dealer and/or parts department must be retained and a copy presented to DIRTcar for verification.
 - g. Overbores will not be permitted. If a cylinder has scoring and/or needs repair it must be communicated to DIRTcar officials before being sleeved to maintain the original bore size.
 - h. Valve jobs will not be permitted.
 - i. If the cylinder head requires resurfacing and/or valve seats, a new cylinder head must be purchased. Machine work of any type will not be permitted to the cylinder heads.
 - j. Bead blasting and/or any polishing and/or any alteration to the intake manifold and/or cylinder heads will not be permitted.
 - k. All engine information regarding repairs and/or engine introduction must be retained and turned into DIRTcar Officials, to track and manage engine database, including the driver, serial number, repair, type of repair and/or what type of service was performed to any engine.
 - l. If any repair estimates come back to the DIRTcar Officials that meet and/or exceed 80% of the actual price of a new engine, a new engine must be purchased. The engine that was damaged will no longer be eligible for competition.
- J.)** DIRTcar and/or World Racing Group Supervisory Officials reserve the right to technically inspect, exchange and/or confiscate any GM Crate Engine at any time. Failure to surrender the engine and/or submit the engine for inspection equals disqualification from the event and/or suspension.
- K.)** The intended direction of the GM Crate Engine program is to maintain a cost-effective, affordable racing program. Rebuilding, balancing, blue printing and/or any other alteration made in an attempt to influence the integrity of this program will not be permitted. The judgment and determination of any such decision will be at the sole discretion of DIRTcar and/or World Racing Group Officials.

15.5 W16 Engine Option

- A.) The W16 will be permitted as an optional engine for use within the DIRTcar 358 Modified division. **The W16 must maintain a minimum weight of 2350 lbs after the completion of any event.**
- B.) It is the right of any DIRTcar sanctioned facility to apply these rules as an option for the Optional W16 Engine for use in the 358 division.
- C.) The engine and all components must remain in their original configuration and form as purchased and/or delivered from the Wegner Racing Motorsports. Any alterations to the engine will not be permitted. The Engine must remain as manufactured by Wegner Motorsports. Repairs must be performed by Wegner Motorsports.
- D.) All engines are to remain sealed. The seals must remain unaltered. Tampering, removal, modifications of any type and/or broken factory seals will not be permitted. The W16 must remain unaltered in any way. Tampering with and/or alteration of any seals will not be permitted and is subject to immediate penalty and/or suspension

- E.) .) Only DIRTcar approved MSD Box Part #64316-MSD/DIRT 6ALN fixed 7600 will be permitted. The ignition box must remain unaltered. Only one (1) approved MSD Box will be permitted per car. The ignition box must be in operating and working condition before, during and after the racing event
- F.) All other DIRTcar 358 Modified Engine rules apply, with the exception of the header rule(s). The recommended exhaust headers will be the Schoenfeld Schoenfeld Headers 1122BVLS1-3 NON TRI Y OR Schoenfeld TRI Y 1124lvyls1 OR Beyea NEDMSBTY=LSS2-3
- G.) DIRTcar and/or World Racing Group Supervisory Officials reserve the right to technically inspect, exchange and/or confiscate any Engine at any time. Failure to surrender the engine and/or submit the engine for inspection equals disqualification from the event and/or suspension.
- H.) The intended direction of the W16 Engine program is to maintain a cost-effective, affordable racing program. Any alteration made in an attempt to influence the integrity of this program will not be permitted. The judgment and determination of any such decision will be at the sole discretion of DIRTcar and/or World Racing Group Officials.

15.0-C DIRTcar Sportsman Modified

ANY CAR, TEAM AND/OR DRIVER THAT DOES NOT MEET THESE SPECIFICATIONS AND/OR EQUIPMENT REQUIREMENTS WILL BE SUBJECT TO PENALTIES AS DETERMINED BY THE DIRTcar and/or World Racing Group OFFICIALS.

Note; Unless otherwise noted within Section 15.0-C, the rules remain the same as presented in section 15.0-A.

15.1 Engines

A.) The General Motors (GM) / Chevrolet Performance Engine part number #88958602/19258602 is the only engine permitted in all DIRTcar Sportsman Modified events.

B.) The engine and all components must remain in their original configuration and form as purchased and/or delivered from the factory. Any alterations to the engine will not be permitted. The Engine must remain as manufactured by General Motors with a stock 4"-inch bore. Overbore(s) will not be permitted. Sleeve repair may be permitted with written permission from DIRTcar and/or World Racing Group Officials.

C.) All engines are to remain sealed from the factory. The original factory seals must remain unaltered, Tampering, removal, modifications of any type and/or broken factory seals will not be permitted. The GM Engine must remain unaltered in any way.

D.) The GM Crate Engine seals (bolt-type) must remain unaltered. DIRTcar and/or World Racing Group Officials may require specific sealing and verification of all seals on any GM Crate Engine. Tampering with and/or alteration of any seals will not be permitted and is subject to immediate penalty and/or suspension.

E.) Only GM replacement parts of any type will be permitted for any type of replacement and/or repair work. Only GM Crate Engine specific valve springs may be used for replacement and/or repair, Part Number # 10212811.

F.) GM Crate Engine repairs must be authorized by DIRTcar. GM Crate Engine repair procedure works as follows:

1.) Contact your track promoter and/or your local track and/or DIRTcar Technical Officials.

2.) The Promoter and/or Technical Officials will specify a repair location and instruct the driver/owner where to take the engine to get an estimate.

3.) Based on the estimate and the detail of the repair, DIRTcar and/or World Racing Group officials will determine if the repairs may be made or if a new engine must be purchased.

4.) If a repair is approved, a specified inspector will inspect the engine and work with the engine repair facility throughout the duration of the repair to ensure that the engine maintains the GM Specifications.

5.) Upon completion of the repair(s) the engine will be 'resealed' before being released for competition.

6.) All parts including the gasket repair kit(s) must be stock OEM Chevrolet Performance replacement parts. The receipt(s) generated from the Chevrolet Performance Dealer and/or parts department must be retained and a copy presented to DIRTcar for verification.

7.) Overbores will not be permitted. If a cylinder has scoring and/or needs repair it must be communicated to DIRTcar officials before being sleeved to maintain the original bore size.

8.) Valve jobs will not be permitted. Valves may be lapped.

9.) If the cylinder head requires resurfacing and/or valve seats, a new cylinder head must be purchased. Machine work of any type will not be permitted to the cylinder heads.

10.) Bead blasting and/or any polishing and/or any alteration to the intake manifold and/or cylinder heads will not be permitted.

11.) The distributor advance curve and/or all parts must remain stock as manufactured.

12.) All engine information regarding repairs and/or engine introduction must be retained and turned into DIRTcar Officials, to track and manage engine database, including the driver, serial number, repair, type of repair and/or what type of service was performed to any engine.

13.) If any repair estimates come back to the DIRTcar Officials that meet and/or exceed 80% of the actual price of a new engine, a new engine must be purchased. The engine that was damaged will no longer be eligible for competition.

G.) DIRTcar and/or World Racing Group Supervisory Officials reserve the right to technically inspect, exchange and/or confiscate any GM Crate Engine at any time. Failure to surrender the engine and/or submit the engine for inspection equals disqualification from the event and/or suspension.

H.) The intended direction of the GM Crate Engine program is to maintain a cost-effective, affordable racing program. Rebuilding, balancing, blue printing and/or any other alteration made in an attempt to influence the integrity of this program will not be permitted. The judgment and determination of any such decision will be at the sole discretion of DIRTcar and/or World Racing Group Officials.

15.1.3 Carburetor / Air Cleaner

A.) Only one (1) 650 cfm Holley carburetor, Part Number 4777 or 80777 or Holley HP Carburetor Part Number 80541-1 will be permitted.

B.) All engines and all components must remain in their original configuration and form as purchased and/or delivered from the factory. Any changes will result in disqualification from the event. Any alterations to the engine will not be permitted.

C.) 4777 and 80777 Option:

- a. The carburetor must maintain the stock venturi and throttle bore dimensions.
- b. The carburetor must maintain all stock dimensions, including mounting and stud location on intake manifold.
- c. The booster height must remain stock OEM from Holley. Cutting, tumbling and/or polishing will not be permitted.
- d. Visible modifications will not be permitted.
- e. The maximum height of the carburetor when measured from the bottom of the carburetor and/or the throttle plate to the machined horizontal surface of block will be in 7"-inches in both the front and rear of the block.
- f. The following alterations will be permitted;
 - i. Holes drilled in the throttle plate for proper idle.
 - ii. Drilling, tapping and plugging of unused vacuum ports.
 - iii. Welding of throttle shaft to linkage arm.
 - iv. Drilling of idle and/or high speed air correction jets.
 - v. Milling of center carburetor body metering block surface, maximum of .015" on each side.
 - vi. Removal of choke plate and shaft.
 - vii. The jets may be changed as needed.

D.) Gauge measurements (go/no-go) must be met at all times, regardless of carburetor temperature.

E.) HP 80541-1 Option:

- a. The carburetor must remain stock retaining all Holley measurements and dimensions. The carburetor may be adjusted utilizing only specified Holley replacement parts.
- b. Jets, bleeds, needle and seat, emulsion bleeds, power valves, accelerator pumps nozzles and accelerator pump cam adjustments will be permitted.
- c. Physical alteration of carburetor components and/or parts and/or any alterations, machining and/or reshaping will not be permitted. The use of epoxy and/or coatings of any kind will not be permitted.

- F.) A single unaltered carburetor spacer plate with an unaltered square hole/opening including gasket with a maximum thickness of 1-1/8"-inch will be permitted. Tapering, machining and/or any other alteration to the spacer plate will not be permitted.
- G.) Only a single conventional round type air cleaner housing will be permitted. Ram air, air box and/or heat shield type devices will not be permitted. The air cleaner must remain in place when the hood is removed.
- H.) Air cleaners that provide ventilation through the top cover (such as the K & N brand) will be permitted.
- I.) Air induction plastic carburetor insert and/or other devices that direct air into the air intake will not be permitted.
- J.) Air diffusers will not be permitted.

15.1.6 Ignition

- A.) Only stock OEM distributors will be permitted. The distributor must maintain the factory mechanical advance curve to stock OEM specifications. Alterations and/or adjustments will not be permitted.
- B.) The ignition amplifier box ("rev box") and coil must be mounted under the hood and on a panel behind the air filter shielded from heat (out of the driver's reach) for ease of inspection. The black wire must be grounded to the motor. When the hood is removed the "rev box" must be clearly visible and not covered.
- C.) The car must be fitted with one (1) unaltered approved MSD/DIRTcar RPM (rev) limiting box. The box and the chip must remain operable and in working condition, prior to, during and after all racing events. **On January 1st, 2016 the MSD 8727CT will be the only MSD/DIRTcar RPM (rev) limiting box permitted for competition.**
- D.) Trigger-type and/or crank trigger-type ignitions will not be permitted.
- E.) The ignition must be mechanically driven in the stock OEM location.
- F.) Only the stock OEM H.E.I. ignition coil will be permitted.
- G.) The wiring must remain as specified by the ignition amplifier box manufacturer.
- H.) One American Passenger Car sized battery with terminals on top and a maximum of 12 volts will be permitted. The battery voltage must not measure more than 14.3 volts. Step up transformer and/or any other device designed to increase voltage will not be permitted.
- I.) OEM stock firing order must be maintained for all engines. Standard GM Firing Order 18436572.
- J.) Ignition amplifier boxes, "rev boxes", RPM limiting chips, may be inspected, confiscated and/or exchanged at any time.
- K.) Traction control devices will not be permitted. Braking devices that control traction will not be permitted.
- L.) DIRTcar and/or World Racing Group officials reserve the rights to analyze and/or switch ignition boxes and/or rev chips at anytime.

15.1.7 Lubrication/Oiling System/Oil Cooler

- A.) Only a single wet sump oil pump will be permitted. Dry sump oil systems will not be permitted.
- B.) Only magnetic steel oil pans will be permitted.
- C.) External type oil pumps and/or vacuum pumps will not be permitted.
- D.) Accu Sumps will not be permitted.
- E.) Engine evacuation systems by internal and/or external driven pumps or by connection between exhaust system and/or valve covers, intake manifold and/or oil pan will not be permitted.

- F.) Oil coolers will be permitted. Please refer to section 15.1.7-A (Big Block section) for mounting location and other rules specific to the oil cooler.

15.1.10 – Driveshaft

- A.) Only magnetic steel drive shafts will be permitted. Titanium and/or aluminum drive shafts and/or drive shaft yokes and/or driveline components will not be permitted.

15.1.11 – Engine Cooling System/Radiator

- A.) Only cast iron water pumps will be permitted.
- B.) **The cooling fan for the radiator must be mounted in the stock OEM location on the front of the water pump. Fans mounted to the crankshaft will not be permitted.** Electric cooling fans and/or pumps will not be permitted.

15.1.12 – Rear End

- A.) **All rear end components, ring and pinion, gear sets and/or any other component, must be specific for the rear end in the car in size. Only full-size type rear ends will be permitted. A minimum of 8"-inch diameter ring gear will be permitted. Miniature rear end housings will not be permitted.**
- B.) Titanium axles and/or any other titanium rear end component will not be permitted.

15.2 Fuel, Fuel Cells and Fuel System

- A.) Fuel coolers of any type will not be permitted.
- B.) **Only 'D'-type VP Racing Gasoline, the official fuel of DIRTcar will be permitted for competition. D-98 will be the only specified fuel permitted at any sanctioned DIRTcar and/or Super DIRTcar Series event. In addition a maximum "94 octane, R+M/2" standard pump gasoline will be permitted. Blending of fuels or gasoline, including VP spec (including 'D') fuels of different octane will not be permitted. Alcohol, methanol, nitrous oxide, nitro-methane and/or propylene oxide will not be permitted. Fuel may be subject to inspection and testing at any time. Proof of purchase for the official fuel of DIRTcar may be required.**
- C.) **Only one mechanical fuel pump in the stock location will be permitted. Fuel must be delivered through the fuel system from the fuel cell to the mechanical fuel pump. Fuel systems that require a return line, a pressure regulator of any type and/or other volume and/or pressure altering device will not be permitted.**

15.3 Exhaust - Muffler and Sound Reduction Devices

- A.) Schoenfeld headers, model number: 1122b, 1122bcm, 4122b and 3122b will be permitted. **Beyea headers Part # NEDM602 will also be allowed.** The exhaust headers must not exceed 1-5/8" in outside diameter. Tri-Y, step headers, stainless steel, coated, ceramic and/or otherwise, and/or merge collectors will not be permitted.
- B.) The permitted mufflers include: Dynamax part number: 17223 and 17296; Extreme Muffler part number(s): 31530 and 31230; Beyea part number(s): MUF3DM.
- C.) The header collector extension pipe and tail pipe must be inserted past the muffler inlet or outlet flange and must exit behind the driver. No Stainless allowed.
- D.) **All Schoenfeld headers must be able to be separated from the rest of the exhaust system for the purpose of inspection.**
- E.) **The complete exhaust system must be sealed. Any type of add on, return system and/or exhaust evacuation system will not be permitted.**

15.6 Weight / Ballast

- A.) All DIRTcar Sportsman Modified must maintain utilizing the GM Crate Engines must maintain a minimum weight;
- Any car utilizing any aluminum wheel(s) must weigh a minimum of 2,450 lbs following the completion of any event.**
 - Any car utilizing all steel wheels must weigh a minimum of 2,400 lbs following the completion of any event.**

- B.) Any track permitting Sportsman Modifieds to compete with the previous 'Open Motor' package, those cars must maintain a minimum overall weight of 2,650 lbs following the completion of any event.
- C.) During all Mr. DIRTcar Sportsman Series events, only the GM 602 Crate Engine will be permitted with a minimum overall weight of 2,450 lbs. "Open Motor" packages will not be permitted to compete in Mr. DIRTcar Sportsman Series events.

15.7 Body

- A.) The letters of the driver's last name must be a minimum of six 6"-inches in height and be positioned under, through and/or above the number on both sides of the car.

15.7.14 Driver Compartment

- A.) Rear panhard bar adjustment devices will not be permitted in the driver compartment. Any rear panhard adjustments that have a knob and/or an adjustment device outside of the cockpit must be wired in a fixed position for competition. Adjustable panhard devices of any type will not be permitted during competition.

15.8 Suspension

15.8.2 Shock Absorbers

- A.) Only the DIRTcar approved –A-B-C type shock absorbers displaying the DIRTcar "Approved" decal will be permitted to compete.
- B.) **Approved Shock Absorbers:** All shock absorbers for the DIRTcar Sportsman Modifieds, DIRTcar Pro Stock, DIRTcar Pro Late Model, DIRTcar UMP Sportsman and DIRTcar UMP Stock Car division must be approved and display an approved designation decal. There will be three types of approved designations, 'A', 'B' and 'C'.

Approved 'A'-type Shock Absorbers:

DIRTcar Sportsman Modified
DIRTcar Pro Stock
DIRTcar Pro Late Model
DIRTcar UMP Sportsman
DIRTcar UMP Stock Car

Pro Shocks – WB and SS Series
Bilstein – AK and SG/SM Series
AFCO – 1020-1034 Series
AFCO – 1273-1295 Series
AFCO – 1473-1497 Series
Integra 421 Series

Approved 'B'-type Shock Absorbers:

DIRTcar Sportsman Modified
DIRTcar Pro Late Model
DIRTcar Pro Stock

Pro Shocks – TA Series
Bilstein – SL/SZ Series
Bilstein – SLS Series
AFCO – 1000 Series
AFCO – 19 Series
AFCO - 24 Series
AFCO - 74 Series
FOX – 983-97-507
FOX – 983-97-509

Approved 'C'-type Shock Absorbers:

DIRTcar Sportsman Modified
DIRTcar Pro Late Model

Pro Shocks – PG Series
Bilstein – SL/SZ Series
Bilstein – SNS Series
AFCO – 1300 Series
AFCO – 2100 Series
Genesis – GD Series (steel body)
Integra – 310-45170 or 310-45190
Advance (ARS) – P/N ARS 2074
Advance (ARS) – P/N ARS 2092
FOX – 983-91-507
FOX – 983-91-509

Shock Absorbers must be submitted to World Racing Group for competition approval prior to the application of the shock absorber designation decal.

15.8.6 Wheelbase and Tread Width

- A.) The maximum front tread width will be 86"-inches with a minimum of 74"-inches. The maximum rear tread width will be 86"-inches with a minimum of 74"-inches. These measurements will be taken from the outside edge of the sidewall of the tires on each side.

15.10 Wheels

- A.) Only one-piece steel and aluminum wheels will be permitted for competition. Magnesium, carbon fiber and/or any other exotic type material will not be permitted.
- B.) The maximum rim width will be 14"-inches when measured from the inside of left bead to the inside of the right bead of the wheel. Only wheels 15"-inches in diameter will be permitted.
- C.) Only beadlocks on the outside of any wheel will be permitted. Any wheel utilizing a beadlock must maintain a minimum diameter hole of 11" or 5" inches inside the beadlock and the wheel. Beadlocks may only be used on the outside of the wheel.
- D.) Wheel covers and/or hubcaps will not be permitted on the inside of the wheel(s). Wheel covers and/or hub caps will be permitted on the outside of the wheel providing they are one piece, **bolted in 3 places to the wheel and/or beadlock** and that they maintain a minimum thickness of .090" with a minimum 1" diameter hole in the center of the cover.
- E.) **Starting with the first 2016 event only steel wheel cover fasteners will be allowed.**
- F.) **It is highly recommended that wheel covers have a minimum of 5 mounting points.**
- G.) Foam inserts (with approved installation) may be permitted. If wheel covers are not properly installed, they may not be permitted.
- H.) A minimum of five (5) lug nuts on the rear wheels will be required. A minimum of three (3) lug nuts will be required on the front wheels. Knock off hubs of any type on any wheel will not be permitted.

15.11 Tires

- A.) Individual race tracks, events and/or series may designate a particular tire and/or compound at any time. The compound may be announced prior to the event in a bulletin and/or at the driver's meeting.
- B.) Only Hoosier Racing Tires will be permitted in any DIRTcar sanctioned events. Hoosier (the tire manufacturer) will mark/stamp/brand all legal tires with specified compound and/or other specific DIRTcar designations as listed below:

DIRTcar Sportsman Modified:

Big Block, 358 Modifieds and Sportsman Modified:

- a) **D300**
- b) **D400**
- c) **D500**

Tire Size and Compound Designation:

- a) **Front - 11/82-15. D300, D400, Allowed**
- b) **Front - 13/82-15. D300, D400, D500 Allowed**
- c) **Rear - 13/87-15. D300, D400 Allowed**
- d) **Rear - 13/89 - 15. D300, D400 Allowed**
- e) **Rear - 13/92-15. D300, D400, D500 Allowed**

- C.) The altering of any tire compound, by any means will not be permitted. Chemical alteration of the tread carcass and/or tread compound, such as tire 'soaking' and or the introduction of tread 'softener' and/or the physical defacement (removal, altering and/or covering) of tire sidewall markings in any manner will not be permitted. If any competitor is found to have altered their tires any penalty deemed appropriate by Super DIRTcar Series and/or DIRTcar Officials may be issued. Tires may be protested by another competitor following the protest rules as stated in section 11.2.
- i. Any tire may be inspected and/or analyzed for alteration at any time. This will consist of a process as determined by the independent laboratory that performs the analysis. A "Chain of

Custody” process will be outlined with the competitor upon inspection of the tires.

- ii. The analysis process will require shipment of the tire to the selected laboratory. Additional race event(s) may be completed before a determination is made. If a penalty is issued, the event(s) that fell into the analysis time period while the tire(s) were being analyzed may be considered as part of the penalty time period.
 - iii. Reference Section 5.3.D. for Competitive Analysis, Section 11.1.I for Penalties and/or Section 11.2.I for Protest(s).
- D.)** Heating of the tires by torch, blanket, heating device(s), exhaust system and/or any other method will not be permitted.
- E.)** Inner liners of any type will not be permitted.
- F.)** A tire durometer may be used during the tire inspection process, provided baseline tire(s) have been read at the event prior to inspection.

15.0-D DIRTcar Pro Stocks

ANY CAR, TEAM AND/OR DRIVER THAT DOES NOT MEET THESE SPECIFICATIONS AND/OR EQUIPMENT REQUIREMENTS WILL BE SUBJECT TO PENALTIES AS DETERMINED BY THE DIRTcar and/or World Racing Group OFFICIALS.

15.1 Engines General and Location

Note: Two engine options will be permitted. Both engine options must use the MSD rev limiter part #87826. The crate option (option A) must use a maximum rev-limiting chip of 6,000 RPM. The open head option (option B) must use a maximum rev-limiting chip of 5,800 RPM.

Crate Engine (Option A);

A.) The General Motors (GM) Engine part number #88958602/19258602 is the only engine permitted in all DIRTcar Pro Stock events.

B.) The engine and all components must remain in their original configuration and form as purchased and/or delivered from the factory. Any alterations to the engine will not be permitted. The Engine must remain as manufactured by General Motors with a stock 4"-inch bore. Overbore(s) will not be permitted. Sleeve repair may be permitted with written permission from DIRTcar and/or World Racing Group Officials.

C.) All engines are to remain sealed from the factory. The original factory seals must remain unaltered, tampering, removal, modifications of any type and/or broken factory seals will not be permitted. The GM Engine must remain unaltered in any way.

D.) The GM Crate Engine seals (bolt-type) must remain unaltered. DIRTcar and/or World Racing Group Officials may require specific sealing and verification of all seals on any GM Crate Engine. Tampering with and/or alteration of any seals will not be permitted and is subject to immediate penalty and/or suspension.

E.) Only GM replacement parts of any type will be permitted for any type of replacement and/or repair work. Only GM Crate Engine specific valve springs may be used for replacement and/or repair, Part Number # 10212811.

F.) GM Crate Engine repairs must be authorized by DIRTcar. GM Crate Engine repair procedure works as follows:

- 1.) Contact your track promoter and/or your local track and/or DIRTcar Technical Officials.
- 2.) The Promoter and/or Technical Officials will specify a repair location and instruct the driver/owner where to take the engine to get an estimate.
- 3.) Based on the estimate and the detail of the repair, DIRTcar and/or World Racing Group officials will determine if the repairs may be made or if a new engine must be purchased.
- 4.) If a repair is approved, a specified inspector will inspect the engine and work with the engine repair facility throughout the duration of the repair to ensure that the engine maintains the GM Specifications.
- 5.) Upon completion of the repair(s) the engine will be 'resealed' before being released for competition.
- 6.) All parts including the gasket repair kit(s) must be stock OEM Chevrolet Performance replacement parts. The receipt(s) generated from the Chevrolet Performance Dealer and/or parts department must be retained and a copy presented to DIRTcar for verification.
- 7.) Overbore will not be permitted. If a cylinder has scoring and/or needs repair it must be communicated to DIRTcar officials before being sleeved to maintain the original bore size.
- 8.) Valve jobs will not be permitted. Valves may be lapped.
- 9.) If the cylinder head requires resurfacing and/or valve seats, a new cylinder head must be purchased. Machine work of any type will not be permitted to the cylinder heads.
- 10.) Bead blasting and/or any polishing and/or any alteration to the intake manifold and/or cylinder heads will not be permitted.
- 11.) The distributor advance curve and/or all parts must remain stock as manufactured.

12.) All engine information regarding repairs and/or engine introduction must be retained and turned into DIRTcar Officials, to track and manage engine database, including the driver, serial number, repair, type of repair and/or what type of service was performed to any engine.

13.) If any repair estimates come back to the DIRTcar Officials that meet and/or exceed 80% of the actual price of a new engine, a new engine must be purchased. The engine that was damaged will no longer be eligible for competition.

G.) DIRTcar and/or World Racing Group Supervisory Officials reserve the right to technically inspect exchange and/or confiscate any GM Crate Engine at any time. Failure to surrender the engine and/or submit the engine for inspection equals disqualification from the event and/or suspension.

H.) The intended direction of the GM Crate Engine program is to maintain a cost-effective, affordable racing program. Rebuilding, balancing, blue printing and/or any other alteration made in an attempt to influence the integrity of this program will not be permitted. The judgment and determination of any such decision will be at the sole discretion of DIRTcar and/or World Racing Group Officials.

15.1.3 Carburetor / Air Cleaner

A.) Only one (1) 650 cfm Holley carburetor, Part Number 4777 or 80777 or Holley HP Carburetor Part Number 80541-1 will be permitted.

B.) All engines and all components must remain in their original configuration and form as purchased and/or delivered from the factory. Any changes will result in disqualification from the event. Any alterations to the engine will not be permitted.

B.) 4777 and 80777 Option:

- 1.) The carburetor must maintain the stock venture and throttle bore dimensions.
- 2.) The carburetor must maintain all stock dimensions, including mounting and stud location on intake manifold.
- 3.) The booster height must remain stock OEM from Holley. Cutting, tumbling and/or polishing will not be permitted.
- 4.) Visible modifications will not be permitted.
- 5.) The maximum height of the carburetor when measured from the bottom of the carburetor and/or the throttle plate to the machined horizontal surface of block will be in 7"-inches in both the front and rear of the block.
- 6.) The following alterations will be permitted;
 - a.) Holes drilled in the throttle plate for proper idle.
 - b.) Drilling, tapping and plugging of unused vacuum ports.
 - c.) Welding of throttle shaft to linkage arm.
 - d.) Drilling of idle and/or high speed air correction jets.
 - e.) Milling of center carburetor body metering block surface, maximum of .015" on each side.
 - f.) Removal of choke plate and shaft.
 - g.) The jets may be changed as needed.
- 7.) Gauge measurements (go/no-go) must be met at all times, regardless of carburetor temperature.

C.) HP 80541-1 Option:

- 1.) The carburetor must remain stock retaining all Holley measurements and dimensions. The carburetor may be adjusted utilizing only specified Holley replacement parts.
- 2.) Jets, bleeds, needle and seat, emulsion bleeds, power valves, accelerator pumps nozzles and accelerator pump cam adjustments will be permitted.
- 3.) Physical alteration of carburetor components and/or parts and/or any alterations, machining and/or reshaping will not be permitted. The use of epoxy and/or coatings of any kind will not be permitted.

D.) A single unaltered carburetor spacer plate with an unaltered square hole/opening including gasket with a maximum thickness of 1-1/8"-inch will be permitted. Tapering, machining and/or any other alteration to the spacer plate will not be permitted.

E.) Only a single conventional round type air cleaner housing will be permitted. Ram air, air box and/or heat shield type devices will not be permitted.

F.) Air cleaners that provide ventilation through the top cover (such as the K & N brand) will be permitted.

G.) Air induction plastic carburetor insert and/or other devices that direct air into the air intake will not be permitted.

H.) Air diffusers will not be permitted.

Engine Blocks - Open Motor (Option B) Effective 2018 will no longer be allowed.

A.) Conventional stock type V-8 engines (OEM American long block – GM, Ford and Chrysler) with the cam in the block will be permitted.

B.) The engine must remain in the stock OEM location in the chassis in a vertical and horizontal manner.

C.) For competitors participating with the 'open' engine option, the engine must be from the manufacturer/make of chassis it is mounted in, including all internal parts.

D.) Bow-tie and/or any other performance type blocks will not be permitted.

E.) The DART 'Little M' Sportsman block (part number: 3115111) will be permitted.

D.) The maximum engine setback permitted will be the center of the number of one (1) spark plug hole, on all make engines (the cylinder that is at the front of the engine) may align with the center of the top of the ball joint.

E.) Sliding and/or adjustable engine/motor mounts will not be permitted.

F.) Aluminum engine blocks will not be permitted.

Carburetor (Open Motor – Option –B-)

A.) Only the Holley carburetor, part number 4412 will be permitted. The maximum spacer adapter of 1-1/16"-inches including gaskets will be permitted. Porting, tapering and/or machining of the spacer in any way will not be permitted. Modifications to the carburetor will not be permitted.

B.) Only the Holley Part Number 11180, 10570, 5924 or 5925 Holley Metering blocks will be permitted for use with the Holley 4412 carburetor.

C.) The following carburetor modifications will be permitted. Any modifications not indicated in the following list will not be permitted:

- a.) Holes drilled in the throttle plate for proper idle.
- b.) Drilling, tapping and plugging of unused vacuum ports.
- c.) Welding of throttle shaft to linkage arm.
- d.) Drilling of idle and/or high speed air correction jets.
- e.) Milling of center carburetor body metering block surface, maximum of .015" on each side.
- f.) Removal of choke plate and shaft.
- g.) The jets may be changed as needed.

D.) All cars must have a minimum of two (2) throttle return springs.

E.) Only a single conventional round type air cleaner housing will be permitted. Ram air, air box and/or heat shield type devices will not be permitted.

F.) Air cleaners that provide ventilation through the top cover (such as the K & N brand) will be permitted.

G.) Air induction plastic carburetor insert and/or other devices that direct air into the air intake will not be permitted.

H.) Air diffusers will not be permitted.

15.1.2 Intake Manifold (Open Motor – Option –B-)

A.) The following 4-bbl., single plane intake manifold(s) that permits the mounting of only one four (4) barrel carburetor will be permitted. Welding, the addition of material, epoxy or any other type of alteration will not be permitted. The intake must be a one piece cast iron or aluminum intake manifold.

Chevrolet: Weiland Part #7547, #7547-1 – Edelbrock #5001
Ford: Weiland Part # 7515, #7516 – Edelbrock #5021, #5081 and #2760
Chrysler : Weiland Part #7545 – Edelbrock #5076
 W-2 Heads Edelbrock #2920

B.) Only two (2) unaltered carburetor adapters will be permitted;

BRP377
HV301-1

D.) Porting of all listed intake manifolds will be permitted. Material may not be added. The maximum height of the carburetor when measured from the bottom of the carburetor base to the machined horizontal gasket surface of the engine block will be 7"-inches in both the front and rear.

15.1.3 Cylinder Heads (Open Motor – Option –B-)

A.) Only stock OEM North American passenger car V-8 Engines with cast iron blocks and cylinder heads (GM, Ford and Chrysler) will be permitted with the following exceptions.

Cast Iron Ported Cylinder Heads:

A.) Stock OEM American passenger car cylinder heads will be permitted. Chevrolet Vortec and/or Ford GT 40 cylinder heads will not be permitted. The Chevrolet Bow-Tie, Chrysler W-2, Ford Performance and DART 180 cylinder heads that maintain the following rules will be permitted. The cylinder heads may be ported. The addition of material will not be permitted. Intake manifolds may be ported to match the cylinder head only. Factory valve spacing and/or valve angles must remain unaltered.

B.) Cast iron ported cylinder head rules must use only the BRP Carburetor adapter (part number BRP 377) or the Brodix (HV301-1). The adapter must remain unaltered as manufactured. The carburetor must remain in a conventional position (facing forward) at all times.

C.) All parts must have the casting and/or original part numbers on them for identification..

D.) Titanium valves will not be permitted. Valves must be one-piece 11/32" stem diameter +/- .005". Titanium valve spring retainers will be permitted.

E.) Only normally aspirated engines will be permitted.

F.) All engines must maintain the stock bore and stroke combinations.

Engines Maximum Overbore:

Chevy 350 C.I. 4.00" bore x 3.480" stroke. +.070" maximum overbore = 363
Chrysler 360 C.I. 4.00" bore x 3.578" stroke. +.020" maximum overbore = 364
Chrysler 340 C.I. 4.04" bore x 3.313" stroke. +.060" maximum overbore = 350
Ford 351 C.I. 4.00" bore x 3.500" stroke. +.060" maximum overbore = 363

G.) Engines must not pump more than the specified cubic inches.

H.) Reverse rotation engines will not be permitted.

I.) The engine must maintain the stock OEM firing order.

15.1.4 Camshaft (Open Motor – Option –B-)

A.) Any design hydraulic or flat tappet camshaft will be permitted, provided the camshaft remains in a stock location in the engine block. Roller cams, roller gear driven cams, mushroom-type lifters and/or lash caps will not be permitted.

- B.) Stock OEM engines, which utilize shaft rockers as a standard component will be permitted. Shaft rockers and/or stud girdles that are not stock OEM equipment on the engine, will not be permitted.
- C.) Roller type rockers with optional ratios will be permitted.
- D.) The lifters must maintain the stock OEM diameter.
- E.) The lifter bores must remain in the stock OEM positions at the stock OEM angles. The lifter bores may be re-bushed for wear.
- F.) A flat magnetic steel lifter galley plate may be used to prevent engine damage in case of push rod failure.
- G.) Overhead cams and/or similar type applications will not be permitted.

15.1.5 Pistons, Connecting Rods, Crankshaft and Vibration Dampener (Open Motor – Option –B-)

Pistons (Open – Option –B-)

- A.) Any brand, three (3) ring flat top piston will be permitted.
- B.) Coatings of any type will not be permitted.

Connecting Rods (Open – Option –B-)

- A.) Only stock OEM production or aftermarket solid magnetic steel connecting rods will be permitted. Titanium, aluminum and/or billet connecting rods will not be permitted.
- B.) Polished connecting rods will not be permitted.
- C.) The connecting rod length must maintain OEM specifications for the engine block used. I.E.; Chevrolet 5.7"-inches, Chrysler 6.125"-inches and Ford 5.956"-inches.
- D.) The connecting rod type must match the manufacturer's engine. (Chevrolet with Chevrolet, Ford with Ford and Chrysler with Chrysler).

Crankshaft (Open – Option –B-)

- A.) Any magnetic steel or cast iron crankshaft, maintaining the stock stroke for the engine block used will be permitted.
- B.) Lightweight crankshafts will not be permitted.
- C.) The minimum rod and main journal size(s) must maintain the stock OEM size, less undersize for the manufacturer, Chevrolet, Ford or Chrysler.
- D.) Knife-edging, narrowing, cutting down the diameter and/or any other alteration to the crankshaft counter weights will not be permitted.

Vibration Dampener (Open – Option –B-)

- A.) Any magnetic steel or cast iron stock OEM vibration dampener will be permitted. Machining and/or any type of alteration to the vibration dampener will not be permitted.
- B.) Fluid and/or friction dampeners will not be permitted.

15.1.6 Ignition/Battery (For either the Crate – Option –A- and/or Open Motor Option –B-)

- A.) Only stock OEM distributors will be permitted. The rev. box must be mounted under the hood.
- B.) Only the black wire must be grounded to the engine block.
- C.) When utilizing an H.E.I. ignition system, the coil must remain stock OEM and remain in the distributor.
- D.) The ignition for the Crate Engine (option –A-) must remain stock OEM.
- E.) Welding of advance weights and the removal of the vacuum advance for the Open Motor (option –B-) will be permitted.

F.) When the hood is removed, the rev box must be in clear view. Covers of any type, over the motor will not be permitted.

G.) One (1) unaltered DIRTcar approved, **MSD 8727CT will be the only MSD/DIRTcar RPM (rev) limiting box permitted for competition** must remain operable and working condition, prior to, during and after all racing events.

H.) The OEM firing order must be retained. (Standard Chevrolet Firing Order: 18436572).

I.) Traction control devices will not be permitted. Braking devices that control traction will not be permitted.

J.) DIRTcar and/or World Racing Group officials reserve the rights to analyze and/or switch ignition boxes and/or rev chips at anytime.

K.) The ignition switch must be clearly labeled ON/OFF and easily accessible from outside of the car.

L.) Any type of mechanically driven ignition located in the stock position will be permitted.

M.) All cars must be self-starting.

N.) The battery must be securely fastened in place.

O.) The battery must remain completely sealed off from the driver's compartment.

P.) One American Passenger Car sized battery with terminals on top and a maximum of 12 volts will be permitted. The battery voltage must not measure more than 14.3 volts. Step up transformer and/or any other device designed to increase voltage will not be permitted.

Q.) A battery shut-off switch, clearly labeled ON/OFF, is mandatory. The switch must be mounted on the left side inner panel (above the steering post). The knob must be outside the panel and clearly visible and easily accessed from outside of the car. It must be wired to take the power off on the positive and/or 'hot' side of the connection. Reference the diagram in the back of this rule book.

15.1.7 Lubrication/Oiling System/Oil Cooler

A.) Only a single wet sump oil pump will be permitted. Dry sump oil systems will not be permitted.

B.) Only magnetic steel oil pans will be permitted.

C.) External type oil pumps and/or vacuum pumps will not be permitted.

D.) Accu Sumps will not be permitted.

E.) Engine evacuation systems by internal and/or external driven pumps or by connection between exhaust system and/or valve covers, intake manifold and/or oil pan will not be permitted.

F.) Oil coolers that are mounted under the hood will be permitted.

15.1.8 – Transmission/Driveline and Driveline Components

A.) Only approved North American and/or Canadian manufactured manual shift transmissions will be permitted. Automatic and/or automatic-type transmissions will be permitted. Three and/or four speed manual transmissions must have all gears working and must have a single clutch disc mounted in the stock OEM location. Clutch and pressure plate must be a minimum of 10.5" in diameter. No aluminum or lightweight material allowed. Steel only.

B.) Any automatic transmission must have a work stock OEM torque converter with all gears working.

C.) Overdrive and/or under-drive transmissions and/or gears will not be permitted.

D.) Running through reduction gears will not be permitted. The transmission must be direct drive to the rear end.

E.) The transmission must have working gears. Forward, neutral and reverse must be working. From the neutral position and with the motor running, the car must be able to go

forward and/or a backward in a smooth manner. The car must start and move under its own power.

F.) Only magnetic steel flywheels with a stock OEM diameter will be permitted.

G.) Driveline components made of carbon fiber will not be permitted.

H.) Drilling and/or machining and/or grinding of transmission components, gears and/or other components including the case for the purpose of lightening the weight of the transmission will not be permitted.

15.1.8 Scattershield

A.) Magnetic steel scattershield and/or magnetic steel scatter proof bell housing for standard transmissions are required.

B.) Automatic transmission explosion blankets are recommended.

C.) All bell housing must have a 1"-inch diameter inspection hole drilled near the top to permit visual inspection of the flywheel and the converter.

15.1.10 – Driveshaft

A.) Only magnetic steel driveshaft will be permitted. All drive shafts must be painted white and be clearly labeled with the car number on it.

B.) Only one (1) drive shaft connected from the transmission to the center section of the rear end will be permitted.

C.) Two (2) driveshaft hoops a minimum ¼"-inch thick x 2"-inch wide magnetic steel must be mounted to the frame wrapping around the driveshaft. One must be mounted in the front of the driveshaft and the other on the rear that prevents the driveshaft from digging into the track and/or bouncing out or up into the car

D.) Only magnetic steel drive flanges and yokes on the rear end and on the transmission will be permitted.

15.1.11 – Engine Cooling System/Radiator

A.) Only one (1) radiator will be permitted. The radiator must be mounted vertically in front of the engine. The radiator must remain in its stock OEM location between the frame rails.

B.) Plastic radiators will be permitted.

C.) A 25 lb. pressure radiator cap is recommended.

D.) An overflow catch can is required. The overflow cans and/or canisters will not be permitted in the cockpit.

E.) All hose connections require double clamp(s).

F.) It is recommended that all metal fittings/ends/nipples have a barb and a hose clamp to prevent hoses becoming loose and/or completely disconnected.

G.) Only cast iron water pumps will be permitted.

H.) Only magnetic steel radiator fans will be permitted.

I.) Electric fans and/or water pumps will not be permitted.

15.1.12 – Rear End

A.) Stock passenger car rear ends will be permitted. The differential housing must be/remain the stock/OEM location. Truck and limited slip rear ends will not be permitted. **Floater hubs allowed.**

B.) Welded spiders or magnetic steel spools will be permitted. Aluminum spool will not be permitted.

C.) A Ford 9"-inch rear may be installed in any chassis providing it utilizes all of the stock OEM and/or same parts needed to hold in the rear that it replaced.

D.) For rear ends that utilize horseshoe clips and/or retainers to hold the axles in place, it is recommended that they be tack welded to hold them in place and prevent failure and/or the axle falling out.

E.) Torque arms will not be permitted.

F.) All rear end components, ring and pinion, gear sets and/or any other component, must be specific for the rear end in the car in size. Only full-size type rear ends will be permitted. Miniature rear ends and/or rear ends manufactured for the sole purpose of reducing rotating weight by decreasing the actual size of the rear end with the internal components of the rear end will not be permitted.

G.) Only magnetic steel axles will be permitted. **Titanium axles, gun drilled, lightened and/or any other titanium rear end components and/or axles will not be permitted.**

H.) The rear end must be in the same location, front-to-back and centered in the chassis. Offset of the rear end will not be permitted.

QUICK CHANGE REAR END OPTIONS

A.) Quick-change rear end is optional. Must have magnetic steel tubes, aluminum or steel spool allowed. No mini quick changes allowed. **V-8 Midget type rear ends will not be permitted.**

B.) Any magnetic steel tube quick change eight (8) web side bells with magnetic steel tube rear with close 5 bolt patterns to fit with the existing wheels.

15.2 Fuel, Fuel Cells and Fuel System

A.) All cars must have fuel cells that meet and/or exceed SFI 28.1/2 and/or FT3 specifications and must be not be older than five (5) years from the date of manufacture. The fuel cell must have a maximum capacity of 24.5 US gallons and must remain in a rectangle and/or square shape for measuring and calculating capacity. The fuel cell must be mounted securely in its container and centered between the frame rails and located in the trunk area in a fixed location. Pressure tanks on fuel systems will not be permitted. Auxiliary fuel tanks will not be permitted.

B.) The maximum capacity of the fuel when measured empty and/or dry will be measured in cubic inches utilizing the standard formula of length (minus ½"-inch) x width (minus ½"-inch) x depth (minus ½"-inch) will be 5,660 cubic inches.

C.) The foam in the fuel cell must remain unaltered. A minimal cut in the foam will be permitted in the shape of a square or a rectangle. The cut may be no more than 1,000 square inches. The foam must retain the factory cut.

D.) The fuel cell must be enclosed completely in a rectangle and/or square container that is a minimum thickness of 20-gauge magnetic steel. An aluminum container may be used as an option and must be a minimum of .060"-inch in thickness.

E.) The fuel cell and/or the container material around the fuel cell must not be able to expand in any way. Tank panels that are bowed and/or bellied and/or positioned to create additional capacity of the fuel cell will not be permitted. Oversized filter housings, fuel coolers, oversized lines, fuel logs and/or any other device that increases the capacity of the fuel system will not be permitted.

F.) The entire container must be visible for ease of inspection.

G.) Fuel coolers of any type will not be permitted.

H.) The fuel cell must be mounted with a minimum of two (2) .125"-inch thick steel straps a minimum of 1"-inch wide. The straps must cover the entire cell. Fuel cells that are mounted in a square tubing frame will be permitted. A minimum of 5/6"-inch ASTM Grade 8 bolts must be used to mount the fuel cell to the frame.

I.) For the GM Crate Engine only; Only one mechanical fuel pump in the stock location will be permitted. Fuel must be delivered through the fuel system from the fuel cell to the mechanical fuel pump. Fuel systems that require a return line, a pressure regulator of any type and/or other volume and/or pressure altering device will not be permitted.

- J.) The bottom of the fuel cell container must be a minimum of 12"-inches from the ground.
- K.) A horizontal bar a minimum of 1"-inch in diameter and .095" in wall thickness must be mounted behind the fuel cell.
- L.) The fuel pick up must be positioned on the top of the fuel cell and be constructed of steel. The fuel pick up must have a check valve. The vent line must have a check valve.
- M.) Only 'D'-type VP Racing Gasoline, the official fuel of DIRTcar will be permitted for competition. D-98 will be the only specified fuel permitted at any sanctioned DIRTcar and/or Super DIRTcar Series event. In addition a maximum "94 octane, R+M/2" standard pump gasoline will be permitted. Blending of fuels or gasoline, including VP spec (including 'D') fuels of different octane will not be permitted. Alcohol, methanol, nitrous oxide, nitro-methane and/or propylene oxide will not be permitted. Fuel may be subject to inspection and testing at any time. Proof of purchase for the official fuel of DIRTcar may be required.**
- N.) For the purpose of inspection, the driver and/or crew must be prepared to drain fuel upon request for inspection and/or measurement.
- O.) Only mechanical type fuel pumps will be permitted. Fuel injection system(s) and/or electrical fuel pumps and/or any type of pressurized fuel system will not be permitted.
- P.) External filler connections including 'dry-break'-type applications will not be permitted. The rear deck/trunk lid must be removed in order for fuel to be added to the fuel cell. The filler neck must remain enclosed in the trunk area of the car.
- Q.) All fuel lines and fittings should be leak proof and inspected from time-to-time for leaks.
- R.) Onboard fire suppression systems are recommended.
- S.) For the Official Fuel of DIRTcar; the fuel provider's decals must be displayed on both sides of all DIRTcar racecars and a patch is required on the drivers uniform. Logos and/or the presentation of any other fuel manufacturer and/or fuel refinery on the racecar and/or drivers uniform will not be permitted.
- T.) Fuel used for competition in sanctioned DIRTcar events should be purchased at the track, from a trackside vendor. Racing fuel transported in drums will not be permitted on track premises.

15.3 Exhaust - Muffler and Sound Reduction Devices

- A.) Only the Beyea part # MUF2.5DM, Dynamax part #17218, Extreme Mufflers part # 20025 type mufflers will be permitted.
- B.) The exhaust must exit past the driver and the exhaust must flow toward the rear of the car in an upward manner away from the racing surface. Exhaust headers and systems must extend past the driver's seat. Exhaust may exit out the side but must be flush with body panel.
- C.) Mufflers must remain unaltered and/or modified internally and/or externally in any way. The collector extension pipe and tail pipe may not be installed past the inlet and/or outlet flange of the muffler.
- D.) The maximum exhaust pipe diameter will be **3 inches**.
- E.) The complete exhaust system must remain under the car and exit to the rear of the car behind the driver, parallel or away from the racing surface.
- F.) Stock cast iron unaltered exhaust manifolds will be permitted.
- G.) Schoenfeld headers part numbers #135, #135cm, #145, #145cm Chevrolet - #445, #435 Chrysler - Ford #335 allowed. Factory and/or OEM magnetic steel street exhaust manifolds/headers will be permitted.
- H.) The primary pipes must maintain a maximum outside diameter of 1-5/8" from flange to collector. Tri-Y type, merge collectors, ceramic coatings, step headers, stainless steel, pipe wrappings and/or any other header/pipe alteration will not be permitted. The inspector must be able to measure and inspect all pipes.
- I.) Crossover headers (not 180-degree type headers) will be permitted with primary exhaust pipes that maintain a 1-5/8"-inch outside diameter from flange to collector.

J.) The maximum header flange or adapter flange thickness is 3/8"-inch.

K.) Crossover connecting pipes from each bank/side of exhaust system will not be permitted.

L.) Several tracks have a locally enforced decibel rule, which preempt any particular muffler rule. Some tracks may have a maximum sound level rule of 95 decibels at 100 feet. This rule will be enforced by local government agencies. Such decibel rules preempt utilizing the required mufflers in sub-section 15.3.

15.4 Traction Control Devices

A.) All electronic and/or computerized wheel spin and/or ignition retardation and/or acceleration limiting and/or traction control devices of any type will not be permitted.

B.) Adjustable ping control devices, dial a chip controls, timing controls and/or automated throttle controls will not be permitted.

C.) Adjustable restrictor plates will not be permitted.

D.) Remote control components of any-type will not be permitted.

E.) Radios and/or devices for transmitting voice and/or data will not be permitted, unless otherwise authorized prior to any event.

F.) Data acquisition systems will not be permitted.

15.5 Chassis/Frame

A.) The frame must be the same as the body manufacturer. Interchanging will not be permitted.

B.) Uni-bodies may tie sub-frames together; however, if the ties extend through the car, the floor must be completely welded to the tie, to seal off the driver's compartment.

C.) Frames may be repaired where needed but the stock frame rail must remain the stock location. Front clips must remain unaltered. No cutting or modifying other than clearance for fuel pump.

D.) The frame must be stock OEM for the year, make and model of the car.

E.) All cars must have a minimum factory stock wheel base of 107"-inches. Full frame cars with a factory stock wheelbase of over 107"-inches may be shortened between the knockouts, but must maintain a minimum wheelbase of 107"-inches.

F.) Front and/or four wheel drive cars and/or frames will not be permitted.

15.5.1 Steering

A.) The steering column must remain in the stock OEM location as manufactured for the make, model and year.

B.) Steering quickening devices that are commercially manufactured will be permitted. Homemade steering quickening devices of any type will not be permitted.

C.) The steering quickening device must be fully enclosed.

D.) The steering wheel center must be padded.

E.) A flexible, racing type steering wheel with a quick release mounting device is recommended.

15.5.2 Uni-bodied Cars/Frames

A.) A homemade frame may be constructed using a minimum of 2"x3"x.120"-inch thick rectangular magnetic steel tubing. The 3"-inch dimension must be in the vertical position. The tubing must start at the rear of the front stock OEM sub-frame and continue all the way back up over (not under) the rear axle and end where the stock OEM rear sub-frame ended. The frame must be the same as the body manufacturer. Interchanging will not be permitted.

B.) The new frame must be as wide as the original sub-frame.

C.) All springs, sway bars (if used on that particular model) and suspension mounts must be located in the same exact position and manner as they were in the stock OEM frame.

D.) Only stock OEM suspension part must be used.

E.) A rear sway may be used only if it was available on the stock OEM make, model and car.

F.) The suitability of the construction of this frame option regarding welds, cross-members, bracing, roll cage and the stock mounting links will be up to the discretion of the Officials.

15.5.3 – Seat Location and Mounting in Frame

A.) The seat must be mounted and positioned completely to the left of the centerline of the car on the driver's side. Floorboard installations will not be permitted. Seats must be mounted as close to the stock OEM position as possible. A functional padded headrest, built into the seat must be in line with the center of the driver's head.

15.6 Weight / Ballast

A.) All cars will be weighed with the driver seated in the car. The minimum weight permitted before and/or after an on track event will be measured by the track scales. The track scales will be the official scales. All cars found to be light prior to any event, time permitting will be allowed to make the necessary adjustments and represent themselves at the scales. The number of cars to be weighed after an event will be announced at the driver's meeting and/or on the one-way radio. If a car is signaled to go to the scales in any fashion and does not report to the scales at the appropriate time, that car may be disqualified from the event. Any car that is found to be light following time trials and/or a qualifying event will be disqualified from that particular race and may make the necessary adjustments and represent themselves for that car's assigned consolation event. If a car is found to be light after the feature event, that car may be disqualified from the event.

B.) The minimum weight following the completion of any Pro Stock race will be:

- a. For cars utilizing the GM 602 Crate Engine = 3,000 lbs
- b. For cars utilizing the Ported Option = 3,300 lb
- c. For cars utilizing a "Coil Spring Rear Suspension" with any suspension components that are not "Stock OEM" including but not limited to a panhard (track bar), OEM type four (4) link and/or "J"-Bar suspensions = 3,150 lbs.
- d. **After market 4 link suspension not allowed. Must use OEM locating points. No floating birdcages allowed.**

C.) All weights are subject to analysis in any DIRTcar division, to maintain a level competition through each DIRTcar sanctioned division.

D.) If time permits, weight added prior to qualifying and/or the event will be permitted,

E.) All weight and ballast must be positively fastened to the frame rails and must remain stationary during competition. All weight(s) must have a minimum of two (2) 1/2"- inch grade 5 bolts and/or studs passing completely through the weight. Bolts and/or studs must be anchored to a suitable clamp to fasten it to the frame. Bolts and/or studs welded to the frame will not be permitted.

F.) All weights must be painted white and clearly labeled with the car number on it. For the period of one event, competitors may label their weight with white duct tape with the car number clearly labeled on the duct tape.

15.7 Body

BODY STYLE AND DIMENSIONS

ALL MEASUREMENTS WILL BE TAKEN WITH DRIVER AND/ OR WITH OR WITH OUT FUEL. TOLERANCE PERMITTED ON ALL BODY DIMENSIONS IS MAXIMUM OF +/- (PLUS OR MINUS) 1/2"-INCH (ONE-HALF INCH). THIS IS A TOLERANCE, NOT A DIMENSION THAT IS INTENDED TO BE ADDED TO THE BODY DIMENSIONS.

Unless otherwise noted and/or in most instances the exterior body dimensions, measurements, materials and rules are based on the ABC (Approved Body Configuration) rules. The ABC Body Specifications may be found at www.ABCbodies.com.

15.7.1 General Body

A.) Any American and/or Canadian made passenger car from 1968-to-present will be permitted. **The 2005 and newer Ford Mustang and the 2010 Chevrolet Camaro bodies as manufactured by ARP Bodies and/or Five Star Race Car Bodies will be permitted for competition, provided they meet the manufacturers dimensions.** Compacts, foreign cars, trucks, sports cars and/or convertibles will not be permitted. Aftermarket bodies, provided they meet the ABC Body Configuration dimensions, appear stock and match the wheel of the frame being used will be permitted.

B.) The body must be stock appearing and mounted in the stock location on the frame. **Ford or Mopar bodies may be used on a GM chassis only utilizing the GM 602 Crate Engine.** The stock sheet metal or aftermarket body must maintain the OEM fit and appearance. Air dams, skirting, any type of air deflection device and/or aerodynamic enhancing equipment will not be permitted anywhere on the car. Wedge shaped and/or flat body panels and/or sides will not be permitted. **All windows must be cut out and remain open. The covering and/or filling in of any window area will not be permitted.** Body styles and/or body parts may be rejected by Super DIRTcar Series, DIRTcar and/or World Racing Group Officials.

C.) The maximum body width when measured anywhere along the contour of the car will be 82"-inches. The minimum ground clearance will be 5"-inches.

D.) Only magnetic steel or aluminum body parts will be permitted. The hoof, roof and rear roof supports (c-pillars) may be manufactured by an approved supplier from fiberglass.

E.) The roof must be of one-piece construction and maintain stock contour and appearance.

F.) Hood scoops and/or raised hood boxes will not be permitted with the exception of aftermarket fiberglass hoods. The aftermarket fiberglass hood may have a maximum raised surface of 4"-inches in height provided it is pre-manufactured into the design of the hood. Holes cut in the hood for any reason will not be permitted. Lift-off hoods and stock sheet metal trunk decks will be permitted provided they are positively fastened to properly seal off the engine and/or trunk area.

G.) The front and rear bumpers may be the hard rubber type used on new cars. The front nose must be stock appearing. 'DIRT style' noses including part number(s) Performance Bodies; 331040, 281040, 251040, etc., will not be permitted. Front and rear bumper covers must be widened from the stock width. The front nose must not extend further than 47"-inches from the centerline of the front wheels. The tail piece/rear fascia must be stock appearing with a bumper cover. Flat sheet metal will not be permitted.

H.) Full fenders are mandatory. A reasonable radius cut for tire clearance will be permitted. Front fender must be one-piece magnetic steel and/or aluminum **and/or composite type as manufactured by ARP Bodies or Five Star Race Car Bodies will be permitted. The fenders must remain stock in appearance.** The inner fender panels may be removed provided the fender remains positively fastened and secured to the car.

I.) The removal of the dash is permitted, providing that the steering column is adequately secured and remains in its stock location. If a new dashboard is installed, it may not extend any further back than the original OEM dashboard for the make and model of the particular vehicle and must remain even/level (in one plane) all the way across the entire car.

J.) All cars must have a full magnetic steel windscreen with a minimum material thickness of 1/16"-inch and a maximum screen opening of 2"-inches x 1"-inches. Chicken wire and aluminum screens will not be permitted. The screen wire must cover the entire windshield area from left-to-right across the cage and from the top of the roll cage to the hood and/or cowl. Any shields, visors and/or cardboard that blocks visibility through the screen will not be permitted. Any shield, visor and/or cardboard for visibility must not be a part of and/or fastened to the roof.

K.) Mirrors and/or reflecting devices will not be permitted.

L.) Under pans, rear tubing in the rear wheel area, speedway-type bodies and/or air dams/additional air directional devices will not be permitted.

M.) Officials reserve the right to request body panels and/or bumpers to be replaced and/or painted if they do not look presentable and/or have any sharp edges.

15.7.2 Rear Spoiler

- A.) A single rear spoiler mounted on the top, at the rear of the deck lid/trunk will be permitted.
- B.) The rear spoiler must be a one-piece aluminum or two-piece (split in the center vertically) lexan spoiler with a maximum height of 5"-inches.
- C.) The spoiler must follow the contour of the body and may not extend out past the maximum body width.
- D.) Three (3) vertical support(s) fin-type mounted in front of the spoiler will be permitted. These supports may not exceed the maximum height of the spoiler and are limited to 16"-inches in length.

15.7.3 Interior

- A.) A full magnetic steel engine fire wall with a minimum of **20** gauge material thickness is required. All holes in the firewall must be covered to isolate the driver's compartment from the engine compartment.
- B.) A full rear steel fire wall must seal off the driver's compartment from the trunk/fuel cell area. Front and rear fire walls must extend from fender to fender in as straight of a line as possible and spot welded for strength.
- C.) Excessive firewall cutouts and/or tunneling for header/exhaust clearance will not be permitted.
- D.) A full floor board must be retained from the engine firewall to the rear fire wall and from the body, side-to-side (interior door skin to interior door skin). The passenger side floor board may be level from the top of the transmission and drive shaft tunnel, but must not exceed this height, to permit clearance for both exhaust pipes and mufflers. **All interior sheet metal must be spot welded for strength.**
- E.) Angular installations and/or cock pit type applications and/or fabrications, will not be permitted.
- F.) Floor boards with excessive rust must be replaced and/or patched securely and/or covered with sheet metal in the original stock configuration to seal the driver's compartment. Any holes in the floor board for the shifter, etc., must not be any larger than required to facilitate shift pattern.
- G.) Shifter boots are recommended as a sealing device for the driver's compartment.

15.7.4 Car Numbers/Driver Name

- A.) The track and/or series Scoring Director reserves the right to issue and/or change a car number to prevent duplication and/or maintain proper records.
- B.) Team cars must be clearly identifiable from one another and use another number and/or letter.
- C.) All number and letter combinations will be limited to three digits. If three digits are used two (2) shall be the primary numbers/letter.
- D.) Number and/or letter combinations are required on the roof, nose, rear deck and both doors.
- E.) All numbers and letters must be a minimum of 18"-inches high on the roof and/or doors and 8"-inches high for the rear deck and the nose. All numbers and/or letters must be equal in size and displayed legibly whether decal and/or painted.
- F.) The nerf bars must not block the visibility of the number and/or letter combinations.
- G.) The letters of the driver's last name must be a minimum of 6"-inches in height and be positioned under, through and/or above number on both sides of the car.

15.7.16 Bumpers and Rub Rails

Rub Rails

- A.) One (1) horizontal rub rail on each side of the car between the wheels will be permitted.
- B.) The rub rails must be magnetic steel square/rectangular tubing with a maximum dimension of 1"-inch x 2"-inches high.

C.) The rub rails must mount flush against the body panels with each end cut at a 45 degree angle and capped. Sharp edges of any type will not be permitted. Lexan-type rub rails that are securely mounted to the body will be permitted.

Bumpers

A.) Stock front and rear bumpers will be permitted.

B.) The bumpers may be securely reinforced under and that the ends of the splash guard to maintain stock OEM appearance.

C.) The bumpers must be stock appearing for the year, make and model of the car.

D.) Additional upper and/or lower bumper reinforcements that are visible will not be permitted. Any-type of reinforcement must be in line with the bumper and not visible. Outside reinforcements of any type will not be permitted.

E.) All tubing must have rounded corner supports to prevent cars from hooking and/or losing bumpers.

F.) Fabricated front and/or rear bumper that entirely cover the stock-type rubber bumper cover will be permitted.

G.) All cars must have tow hooks. The tow hooks must be easily accessible on both the front and rear of the car.

H.) Front and rear bumpers that are fabricated behind the bumper cover must have two (2) rails, an upper and a lower across the frame for support fabricated from a magnetic steel tubing a minimum of 1-1/2" diameter with a minimum wall thickness of .095"-inches. There must be a minimum of four (4) horizontal uprights positively securing the rails together to support the bumper. Approved mounting and design for bumpers of the this type will be at the discretion of the Super DIRTcar Series and/or DIRTcar official.

15.8 Suspension

A.) Only stock magnetic steel or tubular magnetic steel aftermarket upper A-Frames will be permitted.

B.) Aftermarket tubular upper A-Frames must be one (1) piece magnetic steel with a minimum wall thickness of .095" and remain non-adjustable in any manner.

C.) Only magnetic steel cross shafts will be permitted.

D.) Only stock-type ball joints will be permitted. Adjustable uni-ball type joints will not be permitted. The ball joints must maintain the stock OEM ride height.

E.) Chassis cross-shaft mounts for upper A-Frames may be fabricated and relocated.

F.) Excessive cutting of A-Frames for shock clearance will be at the discretion of the Officials.

G.) As an option for rear coil cars only, a tubular magnetic steel upper rear control arm(s) for adjustment of the pinion angle will be permitted but must be mounted in stock location.

H.) All original stock OEM suspension locating brackets must remain intact and unaltered.

I.) The OEM location and the same type of springs (coil or leaf-type) must be used when the chassis was in the stock OEM format or form.

J.) Front leaf spring mount may have a maximum of four (4) mounting holes or one (1) slotted mounting location for chassis height adjustment.

K.) The rear shackles may have multiple holes for chassis height adjustment.

L.) Coil spring spacers and adjustable lowering blocks will be permitted.

M.) Full frame coil spring cars may use a third upper locating link with an additional panhard bar. The third link must be a centered mount on the rear end (or a single stock or fabricated upper trailing arm could be used in stock location, if desired). The third link must have a single mounting location on the rear end and must be magnetic steel with rod (heim) ends.

N.) The lower trailer arm links may be fabricated and must be mounted in the stock OEM location to both the chassis and the rear end housing.

O.) The panhard bar must be mounted behind the rear end on all race cars other than with the quick change rear end, which may mount as required, attaching to one side of the rear end housing and the other side of the chassis.

P.) Multiple vertical mounting locations for the panhard bar will be permitted.

Q.) All three (3) links may be affixed with rod end bearings, solid mounted or mounted in rubber OEM cartridge suspension joint. Coil springs or shock absorber type links will not be permitted.

R.) Only one (1) jacking bolt per wheel will be permitted.

S.) The spring mounting pads on leaf and/or coil cars must be stock and be welded in one position on the rear end housing.

T.) A sway bar may be used provided it was used in the stock OEM application of the model chassis (not body) during OEM production.

T.) A rear sway bar may be used provided it was used in the stock OEM application of the model chassis (not body) during OEM production.

U.) Any form and/or type of chassis adjustment and/or adjusters in the cockpit will not be permitted.

15.8.1 Front End

A.) Only stock-type components in stock OEM locations will be permitted.

B.) Lowering and/or lifting blocks will not be permitted.

C.) Coil spring spacers will be permitted.

15.8.2 Shock Absorbers

A.) Only one (1) shock per wheel will be permitted.

B.) The shock absorber mounting location is optional. Cantilever mounted shocks will not be permitted.

C.) Coil over shock absorbers will not be permitted.

D.) Only the DIRTcar approved A and -B type shock absorbers displaying the DIRTcar "Approved" decal will be permitted to compete.

E.) Approved Shock Absorbers:

All shock absorbers for the DIRTcar Sportsman Modifieds, DIRTcar Pro Stock, DIRTcar Pro Late Model, DIRTcar UMP Sportsman and DIRTcar UMP Stock Car division must be approved and display an approved designation decal. There will be three types of approved designations, 'A', 'B' and 'C'..

Approved 'A'-type Shock Absorbers:

DIRTcar Sportsman Modified
DIRTcar Pro Stock
DIRTcar Pro Late Model
DIRTcar UMP Sportsman
DIRTcar UMP Stock Car

Pro Shocks – WB and SS Series
Bilstein – AK and SG/SM Series
AFCO – 1020-1034 Series
AFCO – 1273-1295 Series
AFCO – 1473-1497 Series
Integra 421 Series

Approved 'B'-type Shock Absorbers:

DIRTcar Sportsman Modified
DIRTcar Pro Late Model
DIRTcar Pro Stock

Pro Shocks – TA Series
Bilstein – SL/SZ Series
Bilstein – SLS Series
AFCO – 1000 Series
AFCO – 19 Series
AFCO - 24 Series
AFCO - 74 Series
FOX – 983-97-507
FOX – 983-97-509

Approved 'C'-type Shock Absorbers:

DIRTcar Sportsman Modified

Pro Shocks – PG Series
Bilstein – SL/SZ Series

DIRTcar Pro Late Model

Bilstein – SNS Series
AFCO – 1300 Series
AFCO – 2100 Series
Genesis – GD Series (steel body)
Integra – 310-45170 or 310-45190
Advance (ARS) – P/N ARS 2074
Advance (ARS) – P/N ARS 2092
FOX – 983-91-507
FOX – 983-91-509

Shock Absorbers must be submitted to World Racing Group for competition approval prior to the application of the shock absorber designation decal.

15.8.3 Springs

- A.)** The springs must be of the OEM stock-type and the OEM location. (Leaf for leaf, coil for coil, torsion bar for torsion bar.
- B.)** Coil spring cars may convert to leaf spring cars.
- C.)** Helper springs will not be permitted.
- D.)** Only magnetic steel springs will be permitted. Carbon fiber and/or other material will not be permitted.
- E.)** On leaf spring configurations the rear slider mounts will be permitted.
- F.)** Ford, Chevrolet and/or Chrysler cars may interchange springs providing springs maintain the individual specifications and stock OEM application and format.

15.8.5 Brakes

- A.)** All cars must have four (4) wheel hydraulic brakes in good working condition. Random brake inspection may take place throughout the season
- B.)** Rear disc brakes may be installed if that particular manufactured had used disc brakes in production and providing the calipers are stock OEM parts.
- C.)** Carbon fiber, carbon, titanium, ceramic, aluminum pads and/or rotors will not be permitted.
- D.)** Stock size after market rotors on magnetic steel hats to replace the stock OEM rotors will be permitted.
- E.)** Brake bias may be adjustable through the cockpit.
- F.) Right Front brake shut offs; either mechanical or electric, are permitted**
- G.)** Dual master cylinders with proportioning valve and adjustment will be permitted.
- H.)** Drilling of brake rotors, any, front or rear will not be permitted.

15.8.6 Wheelbase and Tread Width

- A.)** The wheelbase must maintain the stock specification for the make, model and type of chassis. The minimum overall wheelbase for both sides of the vehicle will be 107"-inches.
- B.)** The maximum front and rear tread width will be 81"-inches for all cars when measured from the outside of the sidewall to the outside of the sidewall.
- B.)** Rear end offsets will not be permitted. This applies to all four corners of the car.
- D.)** Wheelbase setbacks will not be permitted.

15.9 Roll Cage

- A.)** Only round magnetic steel seamless tubing 1-1/2" with a minimum material thickness of 1/8"-inch or 1-3/4" in outside diameter with a minimum material thickness of .095"-inches will be permitted.
- B.)** The basic configuration of the roll cage must be one of 'standard-type' racing application. There are multiple variations common to motorsports applications. Approved roll cage design

is at the discretion of the Track, Super DIRTcar Series, DIRTcar and/or World Racing Group Official(s).

C.) A six (6)-point cage surrounding the driver with uprights mounted on the right and left side of the frame is mandatory. One upright in front and upright behind the driver on each side of the frame. The uprights must be welded to the flat horizontal part of the frame. Welding to the uprights to the kick-ups will not be permitted. The four (4) bars joining the four (4) uprights in a horizontal plane above the driver's head must be a minimum of 2"-inches above the helmet of the driver when seated with seat belts fastened in the car.

D.) There must be a minimum of three (3) horizontal bars on both sides of the car connecting the main uprights. A minimum of one bar on each side must extend to the outer door skin. The horizontal bars must have at least one set of vertical support bars positioned between the main uprights which connect the horizontal bars together.

E.) An additional diagonal bar is recommended from the top left rear of the cage moving downward toward to the right side frame rail.

F.) The above mentioned (A-through-E) roll bars are the minimum requirements. More bars are recommended, but must be approved by an inspector/official.

G.) All junctions of two (2) or more tubes in the cage must be joined with at least 1/8" magnetic steel gussets. Threaded pipe, pipe fittings, and lap weld, soft metals like aluminum, angle iron and/or channel iron will not be permitted. Flush grinding of welds will not be permitted.

H.) All roll cage bars within 18"-inches of the driver, extended arms, legs, head, etc., must be adequately padded for protection. It is recommended that SFI-Rated roll bar padding is utilized in all roll bar padding applications. In addition the steering wheel center must also be padded. It is recommended that this padding be SFI Rated and fire retardant.

I.) Front and rear firewalls constructed from magnetic steel with a minimum thickness of 20-gauge steel are mandatory.

J.) The rear firewall must extend from the top of the window shelf downward and attach to the floorboards. Holes in the firewall will not be permitted.

E.) The front firewall must extend from the dash downward and attach to the floorboards with all holes securely covered with magnetic steel to isolate the driver from the engine compartment.

15.10 Wheels

A.) Only one piece magnetic steel wheels will be permitted with a maximum width of 10"-inches and a 15"-inch diameter for competition. Magnesium, steel, carbon fiber and/or any other exotic type material will not be permitted.

B.) All four (4) wheels must a minimum of five (5) studs and lug nuts. The stud threads must go past the full thickness of the wheel nut on all four corners of the car.

C.) A single beadlock on the right rear will be the only tire permitted to utilize a beadlock.

D.) Wheel offset, front and/or rear, will be a minimum of 3"-inches and a maximum of 4"-inches on either side. The tolerance will be a maximum of 1/4"-inch.

E.) Wheel centers may not be altered.

F.) Starting with the first 2016 event only steel wheel cover fasteners will be allowed.

G.) It is highly recommended that wheel covers have a minimum of 5 mounting points.

15.11 Tires

A.) Individual race tracks, events and/or series may designate a particular tire and/or compound at any time. The compound may be announced prior to the event in a bulletin and/or at the driver's meeting.

B.) Only Hoosier Racing Tires will be permitted in any DIRTcar sanctioned events. Hoosier (the tire manufacturer) will mark/stamp/brand all legal tires with specified compound and/or other specific DIRTcar designations as listed below;

DIRTcar Pro Stocks:

Front or Rear Tires;

1. "M45"
2. "D50"
3. "D60"

Tire Size and Compound Designation:

Front or Rear Tires;

1. 11/87-15 M45, D50
2. 11/90-15 M45, D50, D60

- C.) The altering of any tire compound, by any means will not be permitted. Chemical alteration of the tread carcass and/or tread compound, such as tire 'soaking' and or the introduction of tread 'softener' and/or the physical defacement (removal, altering and/or covering) of tire sidewall markings in any manner will not be permitted. If any competitor is found to have altered their tires any penalty deemed appropriate by Super DIRTcar Series and/or DIRTcar Officials may be issued. Tires may be protested by another competitor following the protest rules as stated in section 11.2.
- D.) Any tire may be inspected and/or analyzed for alteration at any time. This will consist of a process as determined by the independent laboratory that performs the analysis. A "Chain of Custody" process will be outlined with the competitor upon inspection of the tires.
- E.) The analysis process will require shipment of the tire to the selected laboratory. Additional race event(s) may be completed before a determination is made. If a penalty is issued, the event(s) that fell into the analysis time period while the tire(s) were being analyzed may be considered as part of the penalty time period.
- F.) Reference Section 5.3.D. for Competitive Analysis, Section 11.1.1 for Penalties and/or Section 11.2.1 for Protest(s).
- G.) Removable duct tape, provided it does not deface the tire, to cover the D-Number will be permitted.
- H.) Heating of the tires by torch, blanket, heating device(s), exhaust system and/or any other method will not be permitted.
- I.) Inner liners of any type will not be permitted.
- J.) A tire durometer may be used during the tire inspection process, provided baseline tire(s) have been read at the event.

15.12 Personal Safety Equipment – see section 3.0

15.13 Other

- A.) Cars will not be permitted to make a qualifying attempt without passing technical inspection. All cars must be available for inspection prior to the time of the driver's meeting. Following the driver's meeting, covers of any-type on the racecar will not be permitted.
- B.) All fuel lines, power steering lines and/or fittings running through the driver's compartment must be made from an approved braided type line. Plastic and/or glass fuel filters will not be permitted.
- C.) All cars may be subject to technical inspection at any time.
- D.) Full or partial car covers will be permitted only when there is inclement weather and/or the car is in its designated pit stall. All covers shall be removed prior to the car leaving its designated pit stall.
- E.) SFI-approved and labeled seat, roll bar, knee and steering pads and/or padding is recommended.
- F.) All teams must have a fire extinguisher in the rear of their transporter with the car number clearly visible on the extinguisher. The fire extinguisher must be a minimum of 20lbs and is recommended to FFF type chemical and/or DuPont FE-36 and/or equivalent.

- G.) All drivers are required to have a one-way radio. The one-way radio must be working and active prior to any 'on-track' activity. Two-way radios, crew-member to driver and/or any other means of electronic communication, other than the one-way radio provided by the Super DIRTcar and/or DIRTcar Northeast, will not be permitted.
- H.) Seven (7) days prior to any scheduled and/or sanctioned one (1) day DIRTcar Northeast Series event paying less than \$20,000-to-win race teams will not be permitted to rent, test and or attend any practice session(s) at the scheduled track. Any race team and/or driver in violation will be given one (1) lap of qualifying and the best the qualifying position that will be earned is 50% + 1 of the entered cars for that event.

15.14 Series Decal and Patches

- A.) All participants will be required to display decals as provided on the decal verification sheet prior to entering into competition. If any required decal is not displayed loss of any awarded money will be the penalty.
- B.) A series decal is required on both sides of the car. Driver must display the series patch on their uniform to receive point fund awards.
- C.) Contingency and sponsorship awards, any team participating must meet the requirements of the award(s) such as decals, patches, product use and verification. There will be a written deadline presented to the teams prior to the start of each season for each element to be in place for the award requirements. If it is an existing program it will roll over from the prior season and the program will begin at the first race of the season.

16.0 Drawings

- A.) – 1 – Top View
- B.) – 2 – Side View
- C.) – 3 – Spoiler Support
- D.) -4- Rear Roof Support

15.0-E DIRTcar Stock Cars (Northeast)

ANY CAR, TEAM AND/OR DRIVER THAT DOES NOT MEET THESE SPECIFICATIONS AND/OR EQUIPMENT REQUIREMENTS WILL BE SUBJECT TO PENALTIES AS DETERMINED BY THE DIRTcar and/or World Racing Group OFFICIALS.

15.1 Engines General and Location

Note: Two engine options will be permitted. The maximum distance an engine may be setback will be when the center of the number one spark plug hole, on all make engines (furthest cylinder forward) is in line with the center of the top ball joint.

- A.) Throttle Linkage:** Solid rod type throttle linkages will be permitted.. Throttle cables will not be permitted for event. The throttle linkage must have dual throttle return springs.
- B.) Coatings:** Coatings of any type, on any engine part will not be permitted.
- C.) Fuel Pumps:** Only stock OEM metal type or after market replacements will be permitted. Glass bowls, high volume pumps requiring a pressure regulator or any other type of similar fuel pump will not be permitted.

15.2a Crate Engine (Option A):

- A.)** The General Motors (GM) Crate Engine part number #88958602/19258602 is the only engine permitted in all DIRTcar Sportsman Modified events.
- B.)** The GM Crate Engine must remain as manufactured by General Motors with a stock 4"-inch bore. Overbore(s) will not be permitted. Sleeve repair may be permitted with written permission from DIRTcar and/or World Racing Group Officials.
- C.)** The GM Crate Engine must remain unaltered from the distributor in any way.
- D.)** The GM Crate Engine seals (bolt-type) must remain unaltered. DIRTcar and/or World Racing Group Officials may require specific sealing and verification of all seals on any GM Crate Engine. Tampering with and/or alteration of any seals will not be permitted and is subject to immediate penalty and/or suspension.
- E.)** Only GM replacement parts of any type will be permitted for any type of replacement and/or repair work. Only GM Crate Engine specific valve springs may be used for replacement and/or repair, Part Number # 10212811.
- F.)** GM Crate Engine repairs must be authorized by DIRTcar. GM Crate Engine repair procedure works as follows:
 - 1)** Contact your track promoter and/or your local track and/or DIRTcar Technical Officials.
 - 2)** The Promoter and/or Technical Officials will specify a repair location and instruct the driver/owner where to take the engine to get an estimate.
 - 3)** Based on the estimate and the detail of the repair, DIRTcar and/or World Racing Group officials will determine if the repairs may be made or if a new engine must be purchased.
 - 4)** If a repair is approved, a specified inspector will inspect the engine and work with the engine repair facility throughout the duration of the repair to ensure that the engine maintains the GM Specifications.
 - 5)** Upon completion of the repair(s) the engine will be 'resealed' before being released for competition.
 - 6)** All parts including the gasket repair kit(s) must be stock OEM Chevrolet Performance replacement parts. The receipt(s) generated from the Chevrolet Performance Dealer and/or parts department must be retained and a copy presented to DIRTcar for verification.
 - 7)** Overbores will not be permitted. If a cylinder has scoring and/or needs repair it must be communicated to DIRTcar officials before being sleeved to maintain the original bore size.
 - 8)** Valve jobs will not be permitted. Valves may be hand lapped.
 - 9)** If the cylinder head requires resurfacing and/or valve seats, a new cylinder head must be purchased. Machine work of any type will not be permitted to the cylinder heads.

- 10) Bead blasting and/or any polishing and/or any alteration to the intake manifold and/or cylinder heads will not be permitted.
 - 11) The distributor advance curve and/or all parts must remain stock as manufactured.
 - 12) All engine information regarding repairs and/or engine introduction must be retained and turned into DIRTcar Officials, to track and manage engine database, including the driver, serial number, repair, type of repair and/or what type of service was performed to any engine.
 - 13) If any repair estimates come back to the DIRTcar Officials that meet and/or exceed 80% of the actual price of a new engine, a new engine must be purchased. The engine that was damaged will no longer be eligible for competition.
- G.) DIRTcar and/or World Racing Group Supervisory Officials reserve the right to technically inspect, exchange and/or confiscate any GM Crate Engine at any time. Failure to surrender the engine and/or submit the engine for inspection equals disqualification from the event and/or suspension.
 - H.) The intended direction of the GM Crate Engine program is to maintain a cost-effective, affordable racing program. Rebuilding, balancing, blue printing and/or any other alteration made in an attempt to influence the integrity of this program will not be permitted. The judgment and determination of any such decision will be at the sole discretion of DIRTcar and/or World Racing Group Officials.

15.2.a.1 Carburetor (Crate Engine – Option –A)

- A.) Only one (1) 650 cfm Holley carburetor, Part Number 4777 or 80777 or Holley HP Carburetor Part Number 80541-1 will be permitted
- B.) Holley 4777 and 80777 Option:
 - a. The carburetor must maintain the stock venturi and throttle bore dimensions.
 - b. The carburetor must maintain all stock dimensions, including mounting and stud location on intake manifold.
 - c. The booster height must remain stock OEM from Holley. Cutting, tumbling and/or polishing will not be permitted.
 - d. Visible modifications will not be permitted.
 - e. The maximum height of the carburetor when measured from the bottom of the carburetor and/or the throttle plate to the machined horizontal surface of block will be in 7"-inches in both the front and rear of the block.
 - f. The following alterations will be permitted; Holes drilled in the throttle plate for proper idle.
 - g. Drilling, tapping and plugging of unused vacuum ports.
 - h. Welding of throttle shaft to linkage arm.
 - i. Drilling of idle and/or high speed air correction jets.
 - j. Milling of center carburetor body metering block surface, maximum of .015" on each side.
 - k. Removal of choke plate and shaft.
 - l. The jets may be changed as needed.
- C.) Gauge measurements (go/no-go) must be met at all times, regardless of carburetor temperature.
- D.) HP 80541-1 Option:
 - a. The carburetor must remain stock retaining all Holley measurements and dimensions. The carburetor may be adjusted utilizing only specified Holley replacement parts.
 - b. Jets, bleeds, needle and seat, emulsion bleeds, power valves, accelerator pumps nozzles and accelerator pump cam adjustments will be permitted.
 - c. Physical alteration of carburetor components and/or parts and/or any alterations, machining and/or reshaping will not be permitted. The use of epoxy and/or coatings of any kind will not be permitted.
- E.) A single unaltered carburetor spacer plate with an unaltered square hole/opening including gasket with a maximum thickness of 1-1/8"-inch will be permitted. Tapering, machining and/or any other alteration to the spacer plate will not be permitted.

15.2b Open Motor (Option B):

- A.) Only American manufactured and/or made V-8 standard push rod engines will be permitted.
- B.) All engines must maintain the stock bore and stroke combinations with the following exceptions:
Engines Maximum Overbore:
 - a. Chevy 350 C.I. 4.00" bore x 3.480" stroke. +.070" 363 Maximum C.I.
 - b. Chrysler 360 C.I. 4.00" bore x 3.578" stroke. +.020" 364 Maximum C.I.
 - c. Chrysler 340 C.I. 4.04" bore x 3.313" stroke. +.060" 350 Maximum C.I.
 - d. Ford 351 C.I. 4.00" bore x 3.500" stroke. +.060" 363 Maximum C.I.**Engines must not pump more than the specified cubic inches.**
- C.) All engine parts must remain stock OEM, including all blocks and internal parts. Aluminum blocks will not be permitted.
- D.) Conventional stock type V-8 engines (OEM American long block – GM, Ford and Chrysler) with the cam in the block will be permitted.
- E.) The engine must remain in the stock OEM location in the chassis in a vertical and horizontal manner.
- F.) For competitors participating with the 'open' engine option, the engine must be from the manufacturer/make of chassis it is mounted in, including all internal parts.
- G.) Bow-tie and/or any other performance type blocks will not be permitted.
- H.) The DART 'Little M' Sportsman block (part number: 3115111) will be permitted.
- I.) Sliding and/or adjustable engine/motor mounts will not be permitted.

15.2b.1 Carburetor (Open Motor – Option B)

- A.) Only the Holley carburetor, part number 4412 will be permitted. The maximum spacer adapter of 1-1/16"-inches including gaskets will be permitted. Porting, tapering and/or machining of the spacer in any way will not be permitted. No HP carburetor parts allowed on "open" cast engines. No modifications of any kind will be allowed to these carburetors except those listed below (box stock only).
- B.) The following carburetor modifications will be permitted. Any modifications not indicated in the following list will not be permitted;
 - a.) Holes drilled in the throttle plate for proper idle.
 - b.) Drilling, tapping and plugging of unused vacuum ports.
 - c.) Welding of throttle shaft to linkage arm.
 - d.) Drilling of idle and/or high speed air correction jets.
 - e.) Milling of center carburetor body metering block surface, maximum of .015" on each side.
 - f.) Removal of choke plate and shaft.
 - g.) The jets may be changed as needed.
- C.) All cars must have a minimum of two (2) throttle return springs.
- D.) Only a single conventional round type air cleaner housing will be permitted. Ram air, air box and/or heat shield type devices will not be permitted.
- E.) Air cleaners that provide ventilation through the top cover (such as the K & N brand) will be permitted.
- F.) Air induction plastic carburetor insert and/or other devices that direct air into the air intake will not be permitted.
- G.) Air diffusers will not be permitted.

15.2b.2 Intake Manifold (Open Motor – Option B)

- A.) May be either stock cast iron OEM or one of the following aftermarket alum. 4-bbl. single plane intakes that permits the mounting of only one four (4) barrel carburetor
 - Chevrolet:- Weiland Part #7547, #7547-1 – Edelbrock #5001
 - Ford:- Weiland Part # 7515, #7516 – Edelbrock #5021, #5081 and #2760
 - Chrysler- Weiland Part #7545 – Edelbrock #5076

W-2 Heads- Weiand Part #2920

- B.) Only two (2) unaltered carburetor adapters will be permitted;
BRP377
HV301-1
- C.) No porting/ polishing of any type will be allowed to the intake in this division.

15.2b.3 Cylinder Heads (Open Motor – Option –B-)

- A.) **Cylinder heads eligibility:** SPECIAL NOTE-Only cylinder heads produced by Chevy, Chrysler, or Ford prior to 1996 with their part and casting numbers approved by DIRT and pass the ball check will be permitted for competition. Chevy Vortec and Ford GT cylinder heads will not be permitted. Cast Iron OEM stock production cylinder heads only.
- B.) The cylinder heads must be manufactured by manufacturer of engine block. Sand blasting, bead blasting, acid dipping, porting, polishing, and welding will not be permitted.
- C.) Relieving or enshruding of valves in combustion chamber will not be permitted. Any angle valve job will be permitted as long as it is done on a machine that is concentric to the valve guide center.
- D.) Any amount of valve seats per cylinder head will be permitted. allowed to be installed for the purpose of repairing a head.
- E.) Hand grinding, sanding, blending, or de-burring where a cutter or stone leaves off will not be permitted.
- F.) The amount of metal you will be able to remove in the bowl areas on both intake and exhaust will be governed by the same method used by all DIRTcar inspectors at all DIRTcar sanctioned tracks. The method of inspection will be as follows: on the exhaust side, the header will have to be removed and then the inspector will place a tool in the port which will consist of a .531" diameter ball bearing welded to a flexible shaft. With the valve fully opened, the ball will be place against the valve stem and moved to a full circle around the valve stem. If the ball goes past the valve seat, it will the cylinder head will be considered illegal. On the intake side, with the carburetor removed and in some cases, the intake manifold, to maintain a consistent, the ball size will be .787".
 - a. **Note:** These methods of inspection of the cylinder hold will remain consistent regardless of the engine temperature.
- G.) Carbon fiber parts of any type will not be permitted.
- H.) The following valve stem diameters will be the minimum and maximum permitted plus or minus .005": Chevy 11/32"-Ford 11/32"-Chrysler 3/8". Milling or angle milling of the cylinder head to any amount will be permitted. Epoxy and/or coating of heads will not be permitted.
- I.) Rocker arm studs may be pinned. Screw-in studs will be will be permitted.

15.2b.4 Camshaft (Open Motor – Option –B-)

- A.) Any design hydraulic or flat tappet camshaft will be permitted, provided the camshaft remains in a stock location in the engine block. Roller cams, roller gear driven cams, mushroom-type lifters and/or lash caps will not be permitted.
- B.) The lifters must maintain the stock OEM diameter.
- C.) The lifter bores must remain in the stock OEM positions at the stock OEM angles. The lifter bores may be re-bushed for wear.
- D.) A flat magnetic steel lifter galley plate may be used to prevent engine damage in case of push rod failure.
- E.) Overhead cams and/or similar type applications will not be permitted.

15.2b.5 Pistons, Connecting Rods, Crankshaft and Vibration Dampener (Open Motor – Option B)

15.2b.5.1 Pistons (Open – Option –B-)

- A.) Flat top O.E.M. pistons will be permitted. Only two (2) or four (4) valve relief will be permitted. Pop-up type pistons will not be permitted. A forged piston may be used.
- B.) Coatings of any type will not be permitted.

15.2b.5.2 Connecting Rods (Open – Option –B-)

- A.) Only stock OEM production or aftermarket solid magnetic steel connecting rods will be permitted. Titanium, aluminum and/or billet connecting rods will not be permitted.
- B.) Polished or de-burring of connecting rods will not be permitted.
- C.) The connecting rod length must maintain OEM specifications for the engine block used. I.E.; Chevrolet 5.7"-inches, Chrysler 6.125"-inches and Ford 5.956"-inches.
- D.) The connecting rod type must match the manufacturer's engine. (Chevrolet with Chevrolet, Ford with Ford and Chrysler with Chrysler).

15.2b.5.3 Crankshaft (Open – Option –B-)

- A.) Any magnetic steel or cast iron crankshaft, maintaining the stock stroke for the engine block used will be permitted. Modifications with the exception of balancing will not be permitted.
- B.) Lightweight crankshafts will not be permitted. Lightening or boring will not be permitted. Any crankshaft must weight a minimum of 46 pounds.
- C.) The minimum rod and main journal size(s) must maintain the stock OEM size, less undersize for the manufacturer, Chevrolet, Ford or Chrysler.
- D.) Knife-edging, narrowing, cutting down the diameter and/or any other alteration to the crankshaft counter weights will not be permitted.
- E.) Polishing of the crankshaft will not be permitted.

15.2b.5.4 Vibration Dampener

- A.) Any magnetic steel or cast iron stock OEM vibration dampener will be permitted. Machining and/or any type of alteration to the vibration dampener will not be permitted.
- B.) Fluid and/or friction dampeners will not be permitted.

15.3b.6 Ignition/Battery

- A.) Only Stock O.E.M. ignition systems will be permitted: Stock OEM breaker point or HEI (Electronic Ignition) distributors. After market parts and/or components will not be permitted. MSD boxes and/or MSD distributors and/or aftermarket and/or billet distributors will not be permitted.
- B.) When utilizing an H.E.I. ignition system, the coil must remain stock OEM and remain in the distributor.
- C.) The ignition for the Crate Engine (option –A) must remain stock OEM.
- D.) Welding of advance weights and the removal of the vacuum advance **for the Open Motor (option –B)** will be permitted.
- E.) Covers of any type, over the motor will not be permitted.
- F.) The OEM firing order must be retained. (Standard Chevrolet Firing Order: 18436572).
- G.) Traction control devices will not be permitted. Braking devices that control traction will not be permitted.
- H.) The ignition switch must be clearly labeled ON/OFF and easily accessible from outside of the car.
- I.) All cars must be self-starting.
- J.) Battery must remain in the engine compartment or in the trunk area, sealed from driver's compartment and securely fastened to prevent contact with metal parts and damage in

the event of a roll over or impacts. If located in trunk area, the battery must have external charging post(s) to prevent any type of spark or contact during charging. If in the battery is located in the trunk, the fuel cell must be properly grounded with a strap from fuel cell cap ring to the chassis.

- K.) The battery must be encased in a marine-type battery box and securely fastened in place.
- L.) The battery must remain completely sealed off from the driver's compartment.
- M.) One American Passenger Car sized battery with terminals on top and a maximum of 12 volts will be permitted. The battery voltage must not measure more than 14.3 volts. Step up transformer and/or any other device designed to increase voltage will not be permitted.
- N.) A battery shut-off switch, clearly labeled ON/OFF, is mandatory. The switch must be mounted on the left side inner panel (above the steering post). The knob must be outside the panel and clearly visible and easily accessed from outside of the car. It must be wired to take the power off on the positive and/or 'hot' side of the connection. Reference the diagram in the back of this rule book.

15.4 Exhaust - Muffler and Sound Reduction Devices

- A.) **Exhaust Manifold:** Stock O.E.M. cast iron unaltered exhaust manifolds will be permitted. Only passenger-type mufflers will be permitted. Grinding, polishing, porting, or acid dipping will not be permitted.
- B.) **Mufflers:** All cars must have stock or "California Turbo" mufflers in working condition. Glass pack type mufflers will not be permitted. Mufflers must remain unaltered and/or modified internally and/or externally in any way.
 - 1) The maximum exhaust pipe diameter will be 2-1/2"-inches.
 - 2) The complete exhaust system must remain under the car and exit to the rear of the car behind the driver, parallel or away from the racing surface. The exhaust must exit past the driver and the exhaust must flow toward the rear of the car in an upward manner away from the racing surface. Exhaust systems that face the outside of the car will not be permitted.
- C.) **Headers:** Factory and/or OEM magnetic steel street headers 1 5/8" tube only. Crossover headers (not 180-degree type headers) will be permitted with primary exhaust pipes that maintain a 1-5/8"-inch outside diameter from flange to collector. 180° Headers are NOT allowed. Fully welded exhaust highly recommended.
 - 1) The primary pipes must maintain a maximum outside diameter of 1-5/8" from flange to collector. Tri-Y type, merge collectors, ceramic coatings, step headers, stainless steel, pipe wrappings and/or any other header/pipe alteration will not be permitted. The inspector must be able to measure and inspect all pipes.
 - 2) Crossover connecting pipes from each bank/side of exhaust system will not be permitted.
 - 3) No 2 into 1 exhausts

NOTE: Several tracks have a locally enforced decibel rule, which preempt any particular muffler rule. Some tracks may have a maximum sound level rule of 95 decibels at 100 feet. This rule will be enforced by local government agencies. Such decibel rules preempt utilizing the required mufflers in sub-section 15.4

15.5 Lubrication/Oiling System/Oil Cooler

- A.) Only a single wet sump oil pump will be permitted. Dry sump oil systems will not be permitted.
- B.) Only magnetic steel oil pans will be permitted.
- C.) External type oil pumps and/or vacuum pumps will not be permitted.
- D.) Accu Sumps will not be permitted.

- E.) Engine evacuation systems by internal and/or external driven pumps or by connection between exhaust system and/or valve covers, intake manifold and/or oil pan will not be permitted.
- F.) Oil coolers that are mounted under the hood will be permitted.

15.6 Transmission/Driveline and Driveline Components

15.6.1 Transmissions:

Only approved North American and/or Canadian manufactured manual shift transmissions will be permitted. Automatic and/or automatic-type transmissions will be permitted. Three and/or four speed manual transmissions must have all gears working and must have a single clutch disc mounted in the stock OEM location. Triple disc or aftermarket parts will not be permitted. Only Stock OEM pressure plate will be permitted.

- A.) Any automatic transmission must have a working stock OEM torque converter with all gears working. Mini converters and/or hollow converters will not be permitted. Lock up converters will not be permitted. Ball valve type hydraulic transmission will not be permitted.
- B.) Overdrive and/or under-drive transmissions and/or gears will not be permitted.
- C.) Running through reduction gears will not be permitted. The transmission must be direct drive to the rear end.
- D.) The transmission must have working gears. Forward, neutral and reverse must be working. From the neutral position and with the motor running, the car must be able to go forward and/or a backward in a smooth manner. The car must start and move under its' own power.
- E.) Only magnetic steel flywheels with a stock OEM diameter will be permitted.
- F.) Driveline components made of carbon fiber will not be permitted.
- G.) Removing, Drilling and/or machining and/or grinding of transmission components, gears and/or other components including the case for the purpose of lightening the weight of the transmission will not be permitted.

15.6.2 Scattershield

- A.) Magnetic steel scattershield and/or magnetic steel scatter proof bell housing for standard transmissions are required.
- B.) Automatic transmission explosion blankets are recommended.
- C.) All bell housing must have a 1"-inch diameter inspection hole drilled near the top to permit visual inspection of the flywheel and the converter.

15.6.3 – Driveshaft

- A.) Only magnetic steel driveshaft's will be permitted. All drive shafts must be painted white and be clearly labeled with the car number on it.
- B.) Only one (1) drive shaft connected from the transmission to the center section of the rear end will be permitted.
- C.) Two (2) driveshaft hoops / rings a minimum ¼"-inch thick x 2"-inch wide magnetic steel should be used.
- D.) All cars must have a driveshaft sling behind the transmission, under the front universal (U-Joint) joint that prevents the driveshaft from digging into the track and/or bouncing out or up into the car.
- E.) Only magnetic steel drive flanges on the rear end and on the transmission will be permitted.

15.7 Engine Cooling System/Radiator

- A.) Only one (1) radiator will be permitted. The radiator must be mounted vertically in front of the engine. The radiator must remain in its stock OEM location between the frame rails.

- B.) Plastic radiators will be permitted.
- C.) A 25 lb. pressure radiator cap is recommended.
- D.) An overflow catch can is required. The overflow cans and/or canisters will not be permitted in the cockpit.
- E.) All hose connections require double clamp(s).
- F.) It is recommended that all metal fittings/ends/nipples have a barb and a hose clamp to prevent hoses becoming loose and/or completely disconnected.
- G.) Only cast iron water pumps will be permitted.
- H.) Only magnetic steel radiator fans will be permitted.
- I.) Electric fans and/or water pumps will not be permitted.

15.8 Rear End

- A.) Stock passenger car rear ends will be permitted. The differential housing must be/remain the stock/OEM location. The rear end must be from the same manufacturer as the car in which it is mounted.
- B.) Only welded spiders or magnetic steel spools will be permitted. Aluminum and/or any other type of spool will not be permitted.
- C.) A Ford 9"-inch rear may be installed in any chassis providing it utilizes all of the stock OEM and/or same parts needed to hold in the rear that it replaced.
- D.) For rear ends that utilize horseshoe clips and/or retainers to hold the axles in place, it is recommended that they be tack welded to hold them in place and prevent failure and/or the axle falling out.
- E.) Torque arms will not be permitted.
- F.) Titanium axles and/or any other titanium rear end component will not be permitted.
- G.) The rear end must be in the same location, front-to-back and centered in the chassis. Offset of the rear end will not be permitted.

15.9 Fuel, Fuel Cells and Fuel System

- A.) **Fuel:** Only 'D'-type VP Racing Gasoline, the official fuel of DIRTcar will be permitted for competition. Or a maximum octane will be the only specified fuel permitted at any sanctioned DIRTcar and/or Super DIRTcar Series event. In addition a maximum "94 octane, R+M/2" standard pump gasoline will be permitted. Blending of fuels or gasoline, including VP spec (including 'D') fuels of different octane will not be permitted. Alcohol, methanol, nitrous oxide, nitro-methane and/or propylene oxide will not be permitted. Fuel may be subject to inspection and testing at any time. Proof of purchase for the official fuel of DIRTcar may be required.
- B.) **Fuel Cell:** A maximum 22 gallon capacity fuel cell must be centered in trunk and if trunk floor is removed will not extend below the frame rails behind the rear axle. The fuel cell will be secured with a minimum of two 1" x 1/8" flat steel straps secured by 3/8" bolts. Fuel lines will be made of steel tubing or steel braided hose from fuel cell to carburetor through the center of driver's area with a fuel shut off valve painted a bright color (red, yellow, orange, or white) located next to the driver's seat. OEM rubber fuel hose and OEM fuel tanks will not be permitted. A one-way check valve must be installed in the vent line to prevent spillage in the event of a roll over.
- C.) The entire container must be visible for ease of inspection.
- D.) Fuel coolers of any type will not be permitted.
- E.) The fuel cell must be mounted with a minimum of two (2) .125"-inch thick steel straps a minimum of 1"-inch wide. The straps must cover the entire cell. Fuel cells that are mounted in a square tubing frame will be permitted. A minimum of 5/6"-inch ASTM Grade 8 bolts must be used to mount the fuel cell to the frame.
- F.) The bottom of the fuel cell container must be a minimum of 12"-inches from the ground.

- G.) Only mechanical and/or belt driven fuel pumps will be permitted. Fuel injection system(s) and/or electrical fuel pumps and/or any type of pressurized fuel system will not be permitted.
- H.) All fuel lines and fittings should be leak proof and inspected from time-to-time for leaks.
- I.) Onboard fire suppression systems are recommended.

15.10 Traction Control Devices

- A.) All electronic and/or computerized wheel spin and/or ignition retardation and/or acceleration limiting and/or traction control devices of any type will not be permitted.
- B.) Adjustable ping control devices, dial a chip controls, timing controls and/or automated throttle controls will not be permitted.
- C.) Adjustable restrictor plates will not be permitted.
- D.) Remote control components of any-type will not be permitted.
- E.) Radios and/or devices for transmitting voice and/or data will not be permitted, unless otherwise authorized prior to any event.
- F.) Data acquisition systems will not be permitted.

15.11 Chassis/Frame

- A.) Only American and/or Canadian made sedan vehicles, manufactured from 1968-to-current will be permitted.
- B.) Front wheel drive, compact, sports, foreign cars, trucks or convertibles will not be permitted.
- C.) Independent rear suspensions will not be permitted.
- D.) O.E.M. is defined as Original Equipment Manufacturer.
- E.) Strut or Torque Arm cars will not be permitted.
- F.) Either perimeter or offset chassis will be permitted.
- G.) The frame must be the same as the body manufacturer. Interchanging will not be permitted.
- H.) Uni-bodies may tie sub-frames together, however, if the ties extend through the car, the floor must be completely welded to the tie, to seal off the driver's compartment.
- I.) Frames may be repaired where needed but the stock frame rail must remain the stock location.
- J.) The frame must be stock OEM for the year, make and model of the car.
- K.) All cars must have a minimum factory stock wheel base of 107"-inches. Full frame cars with a factory stock wheelbase of over 107"-inches may be shortened between the knockouts, but must maintain a minimum wheelbase of 107"-inches.
- L.) Front and/or four wheel driver cars and/or frames will not be permitted.

15.11.2 Unibodied Cars/Frames

- A.) A homemade frame may be constructed using a minimum of 2"x3"x.120"-inch thick rectangular magnetic steel tubing. The 3"-inch dimension must be in the vertical position. The tubing must start at the rear of the front stock OEM sub-frame and continue all the way back up over (not under) the rear axle and end where the stock OEM rear sub-frame ended. The frame must be the same as the body manufacturer. Interchanging will not be permitted.
- B.) The new frame must be as wide as the original sub-frame.
- C.) All springs, sway bars (if used on that particular model) and suspension mounts must be located in the same exact position and manner as they were in the stock OEM frame.
- D.) Only stock OEM suspension part must be used.

- E.) A rear sway may be used only if it was available on the stock OEM make, model and car
- F.) The suitability of the construction of this frame option regarding welds, cross-members, bracing, roll cage and the stock mounting links will be up to the discretion of the Officials.

15.11.3 Seat Location and Mounting in Frame

- A.) The seat must be mounted and positioned completely to the left of the centerline of the car on the driver's side. Floorboard installations will not be permitted. Seats must be mounted as close to the stock OEM position as possible. Seat must be a minimum of 25 inches measured from the center of the rear axle, to the rear of the bottom of the racing seat. A functional padded headrest, built into the seat must be in line with the center of the driver's head.

15.11.4 Steering

- A.) The steering column must remain in the stock OEM location as manufactured for the make, model and year.
- B.) Steering quickening devices that are commercially manufactured will be permitted. Homemade steering quickening devices of any type will not be permitted.
- C.) The steering quickening device must be fully enclosed.
- D.) The steering wheel center must be padded.
- E.) A flexible, racing type steering wheel with a quick release mounting device is recommended.

15.12 Weight / Ballast

- A.) All cars will be weighed with the driver seated in the car. The minimum weight permitted before and/or after an on track event will be measured by the track scales. The track scales will be the official scales. All cars found to be light prior to any event, time permitting will be allowed to make the necessary adjustments and represent themselves at the scales. The number of cars to be weighed after an event will be announced at the driver's meeting and/or on the one-way radio. If a car is signaled to go to the scales in any fashion and does not report to the scales at the appropriate time, that car may be disqualified from the event. Any car that is found to be light following time trials and/or a qualifying event may be disqualified from that particular race and may make the necessary adjustments and represent themselves for that car's assigned consolation event. If a car is found to be light after the feature event, that car may be disqualified from the event.

The minimum weight race following the completion of any Stock Car race will be:

For cars utilizing the GM 602 Crate Engine = 2,800 lbs

For cars utilizing the Open Motor Option = 3,000 lbs.

- B.) All weights are subject to analysis in any DIRTcar division, to maintain a level competition through each DIRTcar sanctioned division.
- C.) Weights up to a maximum of 75 lbs must be positively fastened to the frame rails and must remain stationary during competition. All weight(s) must have a minimum of two (2) 1/2"- inch grade 5 bolts and/or studs passing completely through the weight. Bolts and/or studs must be anchored to a suitable clamp to fasten it to the frame. Bolts and/or studs welded to the frame will not be permitted.
- D.) All weights must be painted white and clearly labeled with the car number on it. For the period of one event, competitors may label their weight with white duct tape with the car number clearly labeled on the duct tape.
- E.) Clamp around weights will be permitted.

15.13 Body

- A.) **General Appearance:** Aftermarket Bodies will be permitted, providing they remain stock in appearance and match the wheelbase of the frame being used. The body must be mounted in stock location on frame. Sheet metal and/or aftermarket bodies must

maintain the OEM fit and appearance. Air dams, skirts or other aerodynamic enhancing equipment on the car, front or rear will not be permitted. Bodies, engines and chassis must match manufacturer make and model. Wedge shaped bodies and/or flat body panels will not be permitted. DIRTcar and/or World Racing Group and/or Track Officials reserve the right determine the legality of any body and/or parts.

- B.) BODY STYLE AND DIMENSIONS:** All measurements may be taken with or without driver and/or with or without fuel. There will be a tolerance permitted on all body dimensions is maximum of +/- (plus or minus) ½"-inch (one-half inch). This is a tolerance, not a dimension that is intended to be added to the body dimensions.

Unless otherwise noted and/or in most instances the exterior body dimensions, measurements, materials and rules are based on the ABC (Approved Body Configuration) rules. The ABC Body Specifications may be found at www.ABCbodies.com.

- C.)** Any American and/or Canadian made passenger car from 1968-to-present will be permitted. Compacts, foreign cars, trucks, sports cars and/or convertibles will not be permitted. Aftermarket bodies, provided they meet the ABC Body Configuration dimensions, appear stock and match the wheel of the frame being used will be permitted.
- D.)** The body must be stock appearing and mounted in the stock location on the frame. Ford or Mopar bodies with matching engine may be used on a GM chassis. The stock sheet metal or aftermarket body must maintain the OEM fit and appearance. Air dams, skirting, any type of air deflection device and/or aerodynamic enhancing equipment will not be permitted anywhere on the car. Wedge shaped and/or flat body panels and/or sides will not be permitted. Body styles and/or body parts may be rejected by Super DIRTcar Series, DIRTcar and/or World Racing Group Officials.
- E.)** Mirrors and/or reflective devices will not be permitted.
- F.)** The maximum body width when measured anywhere along the contour of the car will be 82"-inches. The minimum ground clearance will be 5"-inches.
- G.)** Only magnetic steel or aluminum body parts will be permitted. The hoof, roof and rear roof supports (c-pillars) may be manufactured by an approved supplier from fiberglass.
- H.)** The roof must be of one-piece construction and maintain stock contour and appearance.
- I.)** Hood scoops and/or raised hood boxes will not be permitted with the exception of aftermarket fiberglass hoods. The aftermarket fiberglass hood may have a maximum raised surface of 4"-inches in height provided it is pre-manufactured into the design of the hood. Holes cut in the hood for any reason will not be permitted. Lift-off hoods and stock sheet metal trunk decks will be permitted provided they are positively fastened to properly seal off the engine and/or trunk area.
- J.)** Full fenders are mandatory. A reasonable radius cut for tire clearance will be permitted. Front fender must be one-piece magnetic steel and/or aluminum and must remain stock in appearance. The inner fender panels may be removed provided the fender remains positively fastened and secured to the car.
- K.)** The removal of the dash is permitted, providing that the steering column is adequately secured and remains in its stock location. If a new dashboard is installed, it may not extend any further back than the original OEM dashboard for the make and model of the particular vehicle and must remain even/level (in one plane) all the way across the entire car.
- L.)** All cars must have a full magnetic steel windscreen with a minimum material thickness of 1/16"-inch and a maximum screen opening of 2"-inches x 1"-inches. Chicken wire and aluminum screens will not be permitted. The screen wire must cover the entire windshield area from left-to-right across the cage and from the top of the roll cage to the hood and/or cowl. Any shields, visors and/or cardboard that blocks visibility through the screen will not be permitted. Any shield, visor and/or cardboard for visibility must not be a part of and/or fastened to the roof.
- M.)** Mirrors and/or reflecting devices will not be permitted.

- N.) Underpans, rear tubing in the rear wheel area, speedway-type bodies and/or air dams/additional air directional devices will not be permitted.
- O.) Officials reserve the right to request body panels and/or bumpers to be replaced and/or painted if they do not look presentable and/or have any sharp edges.

15.13.1 Rear Spoiler-

- A.) Spoilers allowed of any type will not be permitted.

15.13.2 Interior

- A.) A full magnetic steel engine fire wall with a minimum of 18 gauge material thickness is required. All holes in the firewall must be covered to isolate the driver's compartment from the engine compartment. A full rear steel fire wall must seal off the driver's compartment from the trunk/fuel cell area. Front and rear fire walls must extend from fender to fender in as straight of a line as possible. Excessive firewall cutouts and/or tunneling for header/exhaust clearance will not be permitted.
- B.) A full floor board must be retained from the engine firewall to the rear fire wall and from the body, side-to-side (interior door skin to interior door skin). The passenger side floor board may be level from the top of the transmission and drive shaft tunnel, but must not exceed this height, to permit clearance for both exhaust pipes and mufflers. Angular installations and/or cock pit type applications and/or fabrications, will not be permitted. Floor boards with excessive rust must be replaced and/or patched securely and/or covered with sheet metal in the original stock configuration to seal the driver's compartment. Any holes in the floor board for the shifter, etc., must not be any larger than required to facilitate shift pattern. Shifter boots are recommended to as a sealing device for the driver's compartment.

15.14 Car Numbers/Driver Name

- A.) The track and/or series Scoring Director reserves the right to issue and/or change a car number to prevent duplication and/or maintain proper records.
- B.) Team cars must be clearly identifiable from one another and use another number and/or letter.
- C.) All number and letter combinations will be limited to three digits. If three digits are used two (2) shall be the primary numbers/letter.
- D.) Number and/or letter combinations are required on the roof, nose, rear deck and both doors.
- E.) All numbers and letters must be a minimum of 18"-inches high on the roof and/or doors and 8"-inches high for the rear deck and the nose. All numbers and/or letters must be equal in size and displayed legibly whether decaled and/or painted.
- F.) The nerf bars must not block the visibility of the number and/or letter combinations.

15.15 Bumpers and Rub Rails

15.15.1 Rub Rails

- A.) One (1) horizontal rub rail on each side of the car between the wheels will be permitted.
- B.) The rub rails must be magnetic steel square/rectangular tubing with a maximum dimension of 1"-inch x 2"-inches high.
- C.) The rub rails **must** mount flush against the body panels with each end cut at a 45 degree angle and capped. Sharp edges of any type will not be permitted.

15.15.2 Bumpers

- A.) Stock front and rear bumpers will be permitted.
- B.) The bumpers may be securely reinforced under and that the ends of the splash guard to maintain stock OEM appearance.

- C.) The front and rear bumpers may be the hard rubber type used on new cars. The front nose must be stock appearing. 'DIRT style' noses including part number(s) Performance Bodies; 331040, 281040, 251040, etc., will not be permitted. Front and rear bumper covers must be widened from the stock width. The front nose must not extend further than 47"-inches from the centerline of the front wheels. The tail piece/rear fascia must be stock appearing with a bumper cover. Flat sheet metal will not be permitted.
- D.) The bumpers must be stock appearing for the year, make and model of the car.
- E.) Additional upper and/or lower bumper reinforcements that are visible will not be permitted. Any-type of reinforcement must be in line with the bumper and not visible. Outside reinforcements of any type will not be permitted.
- F.) All tubing must have rounded corner supports to prevent cars from hooking and/or losing bumpers.
- G.) All cars must have tow hooks. The tow hooks must be easily accessible on both the front and rear of the car.

15.16 Suspension

- A.) Aftermarket tubular upper A-Frames must be one (1) piece magnetic steel with a minimum wall thickness of .095" and remain non-adjustable in any manner.
- B.) Only magnetic steel cross shafts will be permitted.
- C.) Only stock-type ball joints will be permitted. Adjustable uni-ball type joints will not be permitted. The ball joints must maintain the stock OEM ride height.
- D.) Chassis cross-shaft mounts for upper A-Frames may be fabricated and relocated.
- E.) Excessive cutting of A-Frames for shock clearance will be at the discretion of the Officials.
- F.) All original stock OEM suspension locating brackets must remain intact and unaltered.
- G.) The OEM location and the same type of springs (coil or leaf-type) must be used when the chassis was in the stock OEM format or form.
- H.) Coil spring spacers will be permitted.
- I.) Only one (1) jacking bolt per wheel will be permitted.
- J.) The spring mounting pads on leaf and/or coil cars must be stock and be welded in one position on the rear end housing.
- K.) A sway bar may be used provided it was used in the stock OEM application of the model chassis (not body) during OEM production.
- L.) Any form and/or type of chassis adjustment and/or adjusters in the cockpit will not be permitted.
- M.) **Coil and Leaf springs:** OEM or after market will be permitted. Only magnetic steel springs will be permitted. Carbon fiber and/or any other composite-type material will not be permitted. Mono leaf springs will not be permitted.

15.17 Shock Absorbers

- A.) Only one (1) shock per wheel will be permitted.
- B.) After market WB shocks allowed. Non-adjustable. Steel bodied after market shocks with welded ends are allowed.
- C.) Non-Adjustable. Gas filled OEM replacement will be allowed.
- D.) Cantilever mounted shocks will not be permitted.
- E.) Coil over shock absorbers will not be permitted.
- F.) *The DIRTcar approved A type shock absorber displaying the DIRTcar "Approved" decal*

will be permitted to compete. All shock absorbers must maintain a suggested manufacturer's MSRP of \$100.00

Approved 'A'-type Shock Absorbers:

DIRTcar Sportsman Modified
DIRTcar Pro Stock
DIRTcar Pro Late Model
DIRTcar UMP Sportsman
DIRTcar UMP Stock Car

Pro Shocks – WB and SS Series
Bilstein – AK and SG/SM Series
AFCO – 1020-1034 Series
AFCO – 1273-1295 Series
AFCO – 1473-1497 Series
Integra 421 Series

Approved Shock Absorbers: All shock absorbers for the DIRTcar Sportsman Modifieds, DIRTcar Pro Stock, DIRTcar Pro Late Model, DIRTcar UMP Sportsman and DIRTcar UMP Stock Car division must be approved and display an approved designation decal.

Shock Absorbers must be submitted to World Racing Group for competition approval prior to the application of the shock absorber designation decal.

15.18 Springs

- A.) The springs must be of the OEM stock-type and the OEM location. (Leaf for leaf, coil for coil, torsion bar for torsion bar.
- B.) Coil spring cars may convert to leaf spring cars.
- C.) Helper springs will not be permitted.
- D.) Only magnetic steel springs will be permitted. Carbon fiber and/or other material will not be permitted. No Mono leaf allowed.
- E.) Ford, Chevrolet and/or Chrysler cars may interchange springs providing springs maintain the individual specifications and stock OEM application and format.

15.19 Brakes

- A.) All cars must have four (4) wheel hydraulic brakes in good working condition. Random brake inspection may take place throughout the season. Three wheel and/or left and/or any shut off configurations and valves will not be permitted.
- B.) Rear disc brakes may be installed if that particular manufacturer had used disc brakes in production and providing the calipers are stock OEM parts.
- C.) Carbon fiber, carbon, titanium, ceramic, aluminum pads and/or rotors will not be permitted.
- D.) Manual brake shut offs will not be permitted.
- E.) Dual master cylinders with proportioning valve and adjustment will be permitted.
- F.) Drilling of brake rotors, any, front or rear will not be permitted.

15.20 Wheelbase and Tread Width

- A.) The wheelbase must maintain the stock specification for the make, model and type of chassis. The minimum overall wheelbase for both sides of the vehicle will be 107"-inches.
- B.) Rear end offsets will not be permitted. This applies to all four corners of the car

15.21 Rollcage

- A.) Only round magnetic steel seamless tubing 1-1/2" with a minimum material thickness of 1/8"-inch or 1-3/4" in outside diameter with a minimum material thickness of .095"-inches will be permitted.
- B.) The basic configuration of the roll cage must be one of 'standard-type' racing application. There are multiple variations common to motorsports applications. Approved roll cage design is at the discretion of the Track, Super DIRTcar Series, DIRTcar and/or World Racing Group Official(s).
- C.) A six (6)-point cage surrounding the driver with uprights mounted on the right and left side of the frame is mandatory. One upright in front and upright behind the driver on each

side of the frame. The uprights must be welded to the flat horizontal part of the frame. Welding to the uprights to the kick-ups will not be permitted. The four (4) bars joining the four (4) uprights in a horizontal plane above the driver's head, must be a minimum of 2"-inches above the helmet of the driver when seated with seat belts fastened in the car.

- D.) There must be a minimum of three (3) horizontal bars on both sides of the car connecting the main uprights. A minimum of one bar on each side must extend to the outer door skin. The horizontal bars must have at least one set of vertical support bars positioned between the main uprights which connect the horizontal bars together.
- E.) An additional diagonal bar is recommended from the top left rear of the cage moving downward toward to the right side frame rail.
- F.) The above mentioned (A-through-E) roll bars are the minimum requirements. More bars are recommended, but must approved by an inspector/official.
- G.) All junctions of two (2) or more tubes in the cage must be joined with at least 1/8" magnetic steel gussets. Threaded pipe, pipe fittings, lap weld, soft metals, like aluminum, angle iron and/or channel iron will not be permitted. Flush grinding of welds will not be permitted.
- H.) All roll cage bars within 18"-inches of the driver, extended arms, legs, head, etc., must be adequately padded for protection. It is recommended that SFI-Rated roll bar padding is utilized in all roll bar padding applications. In addition the steering wheel center must also be padded. It is recommended that this padding be SFI Rated and fire retardant.
- I.) Front and rear firewalls constructed from magnetic steel with a minimum thickness of 18-gauge steel are mandatory.
- J.) The rear firewall must extend from the top of the window shelf downward and attach to the floorboards. Holes in the firewall will not be permitted.
- K.) The front firewall must extend from the dash downward and attach to the floorboards with all holes securely covered with magnetic steel to isolate the driver from the engine compartment.

15.22 Wheels/Tires

- A.) Racing type wheels must be used. All wheels must be magnetic be steel. A minimum width 7", and maximum width 8" diameter for competition. Aluminum, magnesium, steel, carbon fiber and/or any other exotic type material will not be permitted.
- B.) All four (4) wheels must a minimum of five (5) studs and lug nuts. The stud threads must go past the full thickness of the wheel nut on all four corners of the car. Only 1/2" -inch wheel studs and 1"-inch lug nuts will be permitted.
- C.) Steel beadlock allowed on the right front and right rear.
- D.) A maximum offset of 2"-inches will be permitted. All wheels will be measured from the outer bead radius to center of bolt flange. There will be no tolerance.
- E.) Foam or corrugated plastic wheel plugs or covers are permitted.
- F.) Wheel centers may not be altered.

15.22.1 TIRES

- A.) Tires must be street tread only with a maximum of 8" tread width. Snow, mud, studded, light truck and/or directional tires will not be permitted. Radial tires are highly recommended.
- B.) Allowed Options:
 - Street **D.O.T.** Tire, Diameter 70 Series Tire,
 - Hoosier E-Mod 26.5 or 27.5/A-40,
 - D-40 or H-40 and/or DCM 500.



WORLD RACING GROUP SUBSTANCE ABUSE POLICY TERMS AND CONDITIONS

PURPOSE.

The World Racing Group (hereinafter "WRG") is dedicated and committed to making its racing series safe for both competitor and spectators. WRG understands that misuse and abuse of alcohol and drugs, both legal and illegal, is a serious threat to the safety and security of motorsports, and by way of this policy, it seeks to control and eliminate such misuse and abuse at or in connection with its events. WRG requires the cooperation and assistance of all of its competitors and members in effectively implementing the "World Racing Group Substance Abuse Policy" (hereinafter "Policy"). All members, drivers, mechanics, crew members, officials, workers, and others participating in WRG events in any way (hereinafter collectively "Participants") agree to be bound by, and to comply with, the Policy terms and conditions at all WRG events at all times.

II. PROHIBITIONS.

A. Prohibited Substances.

Pursuant to this Policy, prohibited substances include those substances that, in WRG's sole determination, may adversely affect the safety and well-being of the Participants or the competition at a WRG event. Such substances include, but are not limited to, illegal drugs and the paraphernalia associated with the use of illegal drugs. WRG reserves the right, in its sole discretion, to make a determination with regard to the prohibition of any substance at any time. Pursuant to this Policy, said discretion includes the ability of WRG to make the determination after it receives the results of a drug test pursuant to this Policy. Participants shall not use, possess, purchase, sell, manufacture or participate in the distribution of prohibited substances, in any amount and at any time.

B. Prescriptions and Over-the-Counter Medications.

Participants shall use prescription and over-the-counter medications responsibly, and Participants should be fully informed as to the medications' potential impact and effect on participation at WRG events. Participants should not use prescription or over-the-counter medications during WRG event if such use impairs or diminishes their skills or abilities, or if it affects the Participants' safety or the safety of others. Even when properly used, prescription and over-the-counter medications can be dangerous and result in an unsafe environment, particularly during high speed motorsports activities.

Misuse of a prescription or over-the-counter medication by Participants, including, without limitation, use that is inconsistent with the instructions provided by the manufacturer, pharmacist, and/or the prescribing physician, is strictly forbidden. WRG reserves the right and ability to prohibit the use or misuse of any particular prescription or over-the-counter medication, and to deem such use or misuse detrimental to the safety of Participants, the sport, and/or others. Any medication that causes Participants to have a diminished or impaired ability to perform his or her duties at and WRG event shall be deemed to be prohibited for the purpose of this Policy. The illegal acquisition and/or distribution of any prescription or over-the-counter medication is also strictly prohibited.

C. Alcohol.

On event days, Participants in WRG events are strictly prohibited from consuming or being under the influence of alcohol prior to or during the event. Participants shall be deemed under the influence of alcohol if a test taken before, during, or immediately after participation (in any capacity) indicates a blood alcohol content level at or above 20 mg per 100ml (.02%). However, nothing in the terms and conditions of this Policy shall prevent WRG from exercising its sole discretion to determine that a Participant evidencing alcohol usage in any amount (even with a blood alcohol content level of below 20mg per 100ml [.02%]) is under the influence and/or physically unfit for participating in the event. WRG reserves the right and ability to take such action in the interest of safety and in the best interest of the sport.

III. TESTING BASED UPON REASONABLE SUSPICION.

WRG can require a Participant to submit to a test or tests for the presence of alcohol, drugs or medications if a WRG event or sanctioning body official has reasonable suspicion that the Participant has violated any part of this Policy or has impaired or diminished abilities to perform as a result of using a prohibited substance. Pursuant to this Policy, testing may be performed using breath, urine, saliva, and/or blood. WRG also reserves the right and ability to determine that Participants are under the influence of alcohol, drugs, or medications through the use of a physical field test checking physical impairments or diminished capacities.

Circumstances and factors that may cause WRG to have reasonable suspicion include, without limitation the following:

- A. Illegal substances or illegal drug paraphernalia is observed in the possession of the Participant at any time;
- B. The Participant is observed exhibiting one or more of the following symptoms or behaviors, which can potentially be associated with the use of alcohol, drugs, and/or medications:
 - 1) Physical signs of red or droopy eyes, and/or dilated or constricted pupils;
 - 2) Slurred speech, stumbling, or hyperactivity;
 - 3) Needle marks present on the Participant's body;
 - 4) Repeated unexplained disappearances from an event;
 - 5) A constantly running or sniffing nose, or a nose that appears consistently red or irritated;
 - 6) The inability to understand or track time, exhibited, for example, by the Participant being regularly tardy or absent from appointments or commitments;
 - 7) Chronic forgetfulness or broken promise;

- 8) An abnormal number of accident during events;
 - 9) Involvement in conduct which violates WRG safety procedures or involvement in careless acts during a WRG event;
 - 10) Inability to concentrate, lack of recollection, and/or lack of attention;
 - 11) Mental confusion, paranoia, or the presence of abnormal or unreasonable thoughts and ideas;
 - 12) Exhibitions of violent tendencies, loss of temper, irritability, or unreasonably aggressive behavior;
 - 13) Statements by a Participant that may indicate that he or she uses prohibited substances;
 - 14) Extreme personality changes and/or mood swings;
 - 15) Noticeably declining personal hygiene and appearance;
 - 16) A pattern of abnormal conduct;
 - 17) Violation of WRG rules or a failure to follow safe practices; and
 - 18) Evidence of attempts to falsify, alter or modify prior alcohol or drugs tests.
- C. The Participant is charged with, suspected of, or arrested or convicted for driving while under the influence of alcohol, drugs, medications, or other prohibited substances;
- D. The Participants is charged with, suspected of, or arrested or convicted for any type of drug related offense;
- E. The WRG receives information from a reliable source that the Participant is under the influence of alcohol, drugs, medications, or other prohibited substances on the day of a WRG event, or that the Participant is using, possessing, distributing, or selling illegal drugs or other prohibited substances at any time.
- F. The smell of alcohol or other prohibited substance is evident on the person of any Participant on the day of any WRG event.
- G. The results of an examination or test administered by, or at the request of WRG, indicates evidence that the Participant is or was using a prohibited or illegal substance, or the Participants is abusing alcohol;
- H. The Participant attempts to alter or manipulate a specimen used in connected with testing under this Policy, or the Participant attempts to alter or manipulate the results of any such testing or examination.

IV.RANDOM TESTING.

Participants understand and acknowledge that WRG reserves the right and ability to implement (in its sole discretion) a random and/or annual testing procedure and require Participants to submit to such testing. The selection of Participants to submit to random or annual testing shall be made by WRG in WRG's sole discretion.

V.AUTHORIZATION FOR TESTING; WAIVER AND RELEASE; COMPLIANCE.

If a WRG Participant refuses to sign, execute, and/or deliver an authorization for testing in connection with this Policy, and/or the "WRG Substance Abuse Policy Waiver and Release, Express Assumption of the Risk, and Indemnity Agreement" prior to participation in WRG events as required by WRG, the Participant will not be issued membership in, or a license to, WRG, and the Participant will not be permitted to participate in WRG events. In such a circumstance, if a Participant is already a member, and/or already has a WRG license, the Participant will be suspended until he or she complies with all requirements of this Policy.

Upon request pursuant to this Policy, Participants must comply and submit to testing within the time period designated by the WRG officials. If a Participant refuses to comply with or participate in testing within the time period designated by WRG officials, the Participant may be removed from WRG event premises and suspended from competition. In such a circumstance, the Participant will also be subject to additional disciplinary action pursuant to this Policy.

VI.TESTING PROCEDURES.

A. Handling of Specimens

WRG shall designate certain WRG officials with the responsibility to collect test specimens and to carry out the following procedures with due care and diligence:

- 1) To ensure that the specimens are properly designated and are accurately logged and registered from Participants. This may include the observing the specimen collection process.
- 2) To ensure that the specimens are collected within the appropriate and designated time periods. According to this Policy, specimen collections should normally be made within one hour or less of the Participant being notified that testing will be conducted. However, WRG reserves the right to designate a different time period as circumstances require or warrant.
- 3) To ensure that the specimens are not altered or manipulated, including by promptly measuring the temperature of the specimens. WRG may, in its sole discretion deem any particular sample inappropriate for testing and require a Participant to provide additional specimens, as necessary.
- 4) To label, secure, and transport the specimens to WRG's designated testing facility in such a manner as to ensure the integrity of the specimens.
- 5) To obtain forms completed by the Participants in connection with testing, identifying all prescription and over-the-counter medications consumed by the Participant in the preceding three months.

B. Testing Facility.

All testing pursuant to this Policy will be completed at a facility (or facilities) selected by WRG, in its sole discretion, from the listing of those facilities that have been certified by the Substance Abuse and Mental Health Services

Administration of the United States Department of Health and Human Services and/or by the College of American Pathologists Forensic Urine Drug Testing Program (hereinafter the "Facility").

C. Testing Specifics.

The Facility shall determine the appropriate standards and methods of analysis regarding specimens submitted concerning WRG Participants. The Facility shall also determine if, and to what extent, a specimen is deemed to be a true positive for a prohibited substance and/or alcohol, along with whether or not the specimen has been altered or manipulated. The Facility shall transmit all testing results to an official (or officials) designated by WRG for interpretation, and for determination of the appropriate course of action.

VII. POSITIVE TESTS

A. Concerning Prohibited Substances Other Than Alcohol:

- 1) Upon being notified by the designated WRG official (or officials) of a true positive test result for a WRG Participant, the WRG Officials shall suspend the Participants' membership and license with WRG for an indefinite period, and it shall take such other disciplinary action it deems appropriate under the circumstances pursuant to this Policy and WRG rules and guidelines.
- 2) If, following a suspension (and the enforcement of any other disciplinary action), a Participant desires to resume participation in any way in a WRG event, the Participant must obtain approval from the WRG Appeals Board and/or WRG Supervisory Officials and must voluntarily submit himself or herself to follow up, and regularly scheduled, testing as deemed necessary by the WRG Supervisory Officials and/or Board. Such follow up testing shall be conducted in a manner, and under certain conditions, as determined necessary by the WRG Supervisory Officials and/or Board. The follow up testing as determined by the WRG Supervisory Officials and/or Board shall also be conducted solely at the expense of the Participant. In the event that a suspended Participant submits to follow up testing and such testing shows no evidence of a prohibited substance, the WRG Supervisory Officials and/or Board may reinstate the Participant, assuming the Participant is otherwise eligible to participate, and assuming that the Participant agrees to make himself or herself available for future random tests without the need for reasonable suspicion. Such random testing shall be conducted as the WRG Supervisory Officials and/or Board sees fit, shall take place at any time and at any WRG event, and shall be conducted at Participant's sole expense.

B. Concerning Alcohol:

- 1) Upon being notified by the designated WRG official (or officials) that a Participant has consumed alcohol in violation of this Policy, the WRG Supervisory Officials and/or Appeals Board may suspend the Participant's membership and/or license for an indefinite period and/or take such other disciplinary action deemed appropriate under the circumstances.
- 2) If, following a suspension (and the enforcement of any other disciplinary action), a Participant desires to resume participation in any way in a WRG event, the Participant must obtain approval from the WRG Appeals Board and/or Supervisory Officials and must voluntarily submit himself or herself to follow up, and regularly scheduled, testing as deemed necessary by the Board. In the event that a suspended Participant submits to follow up testing and such testing shows no evidence of alcohol or a prohibited substance, the WRG Supervisory Officials and/or the Board may reinstate the Participant, assuming the Participant is otherwise eligible to participate, and assuming that the Participant agrees to make himself or herself available for future random tests without the need for reasonable suspicion. Such random testing shall be conducted as the WRG Supervisory Officials and/or Board sees fit, shall take place at any time and at any WRG event, and shall be conducted at Participant's sole expense.

C. Publication:

Participants agree that WRG may, as it deems reasonable under the circumstances, publish the results of any test or tests conducted pursuant to this Policy and the circumstances giving rise to such test to such third parties. Participants also agree that WRG may, in its discretion, publish information regarding disciplinary action taken as a result of any testing or any violation of the Policy. Participants shall have no claim or cause of action of any kind against WRG or any of its officials, directors, officers, employees or agents with respect to any such publication.

VIII. COMPROMISED TESTS.

A Participant who acts with the intent, and/or does in fact, falsify, alter, or otherwise manipulated with any specimen or any aspect of the testing procedure or process under this Policy will be subject to disciplinary action as issued by the WRG Supervisory Officials and/or WRG Appeals Board. A specimen that is identified as having been falsified, altered, or manipulated shall be treated in the same manner as a true positive test result for a prohibited substance other than alcohol, with all attendant consequences and results as set forth above.

IX. PROHIBITED ACTED UNDER THIS POLICY.

If WRG determines that a Participant has engaged in any prohibited act under this Policy or has acted in a manner contrary to the purpose and intent of this Policy, WRG may remove the Participant from the WRG event premises and/or take any other emergency action as is deemed appropriate under the circumstances. In such a circumstance, the Participant will also be subject to disciplinary action as issued in the discretion of the WRG Supervisory Officials and/or WRG Appeals Board.

X. TREATMENT FOR ALCOHOL, DRUGS, OR MEDICATIONS.

WRG shall not be involved in recommending or prescribing any particular rehabilitation programs or procedures in response to a violation of this Policy. However, WRG strongly encourages Participants in violation of the Policy to obtain professional and ongoing help and assistance. In determining potential reinstatement and future participation, WRG will take into account a Participant's efforts to obtain professional help, and it will consider the results and successful completion of programs and assistance.

XI.WRG RULES.

This Policy, as it may be amended from time to time, serves as a supplement to the currently effective WRG Rules as promulgated by the WRG Supervisory Officials and/or WRG Board of Directors. This Policy shall be interpreted and applied by the WRG in the context of and in connection with the WRG Rules. This Policy is, and shall be, binding upon all WRG members in the same manner, and to the same extent, as the WRG Rules.

DRAWINGS / PHOTO DESCRIPTIONS:

Mandatory Decal Placement all Series:

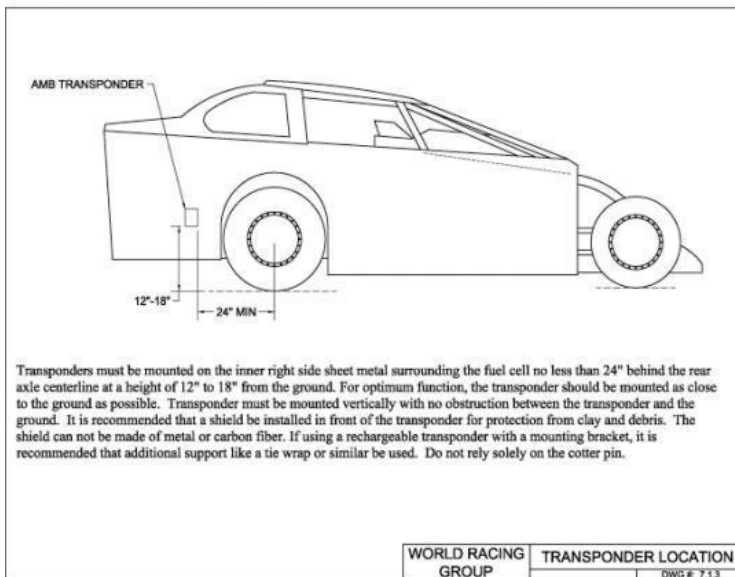
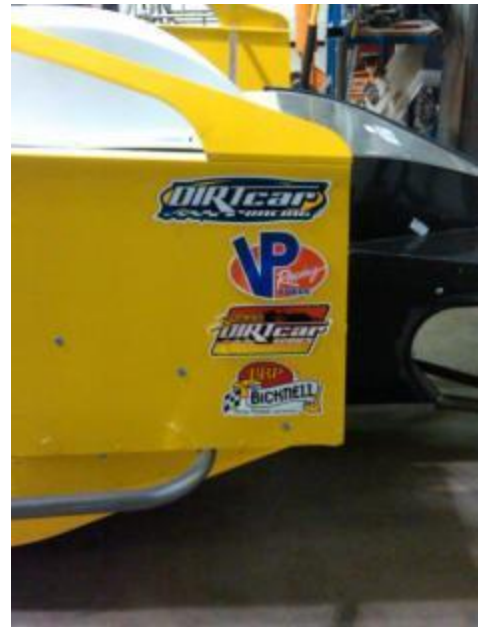

Transponder Location

Body Dimensions

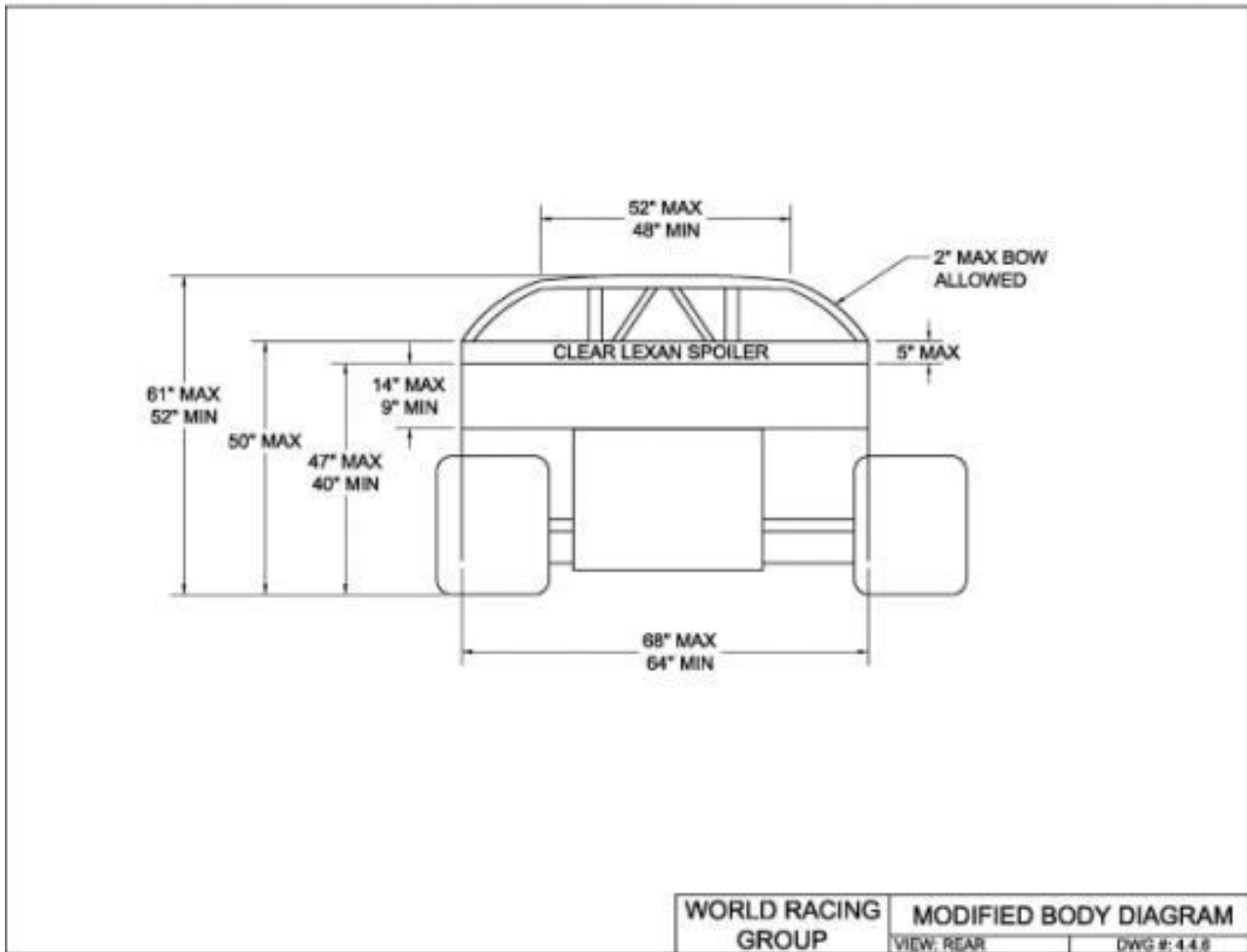
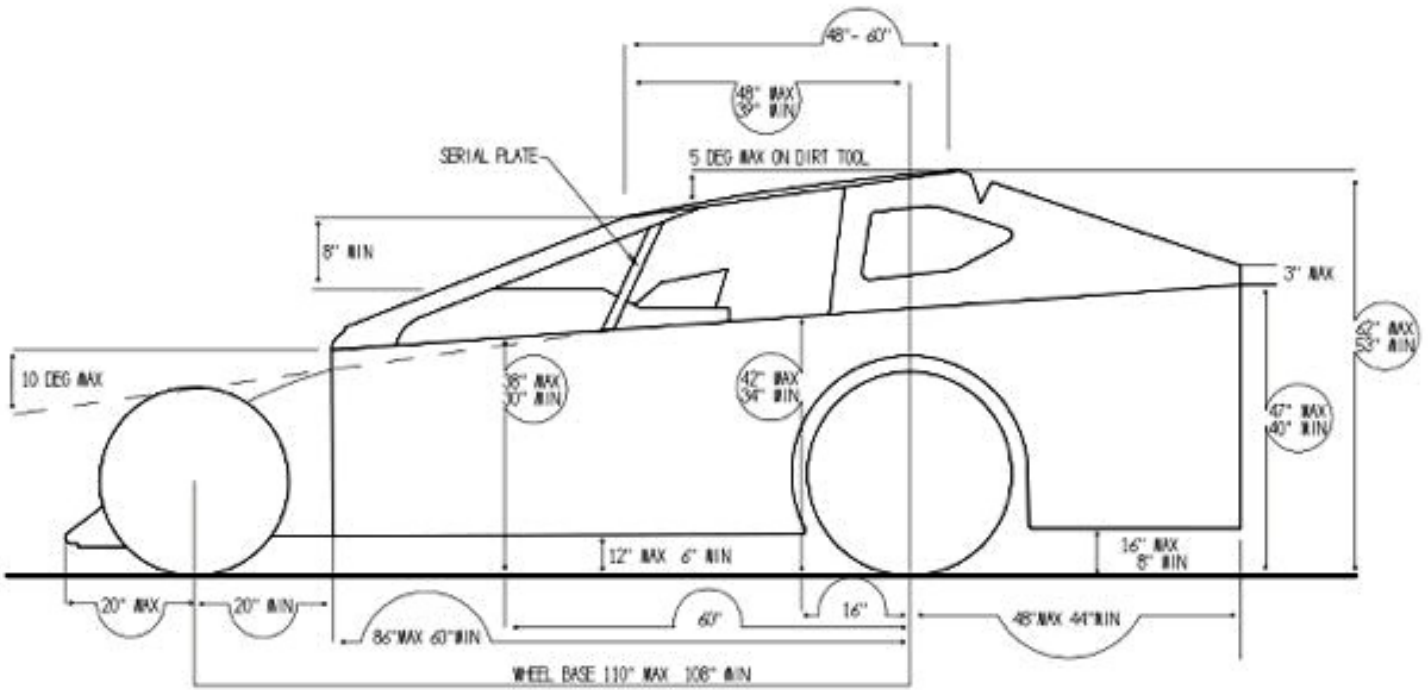

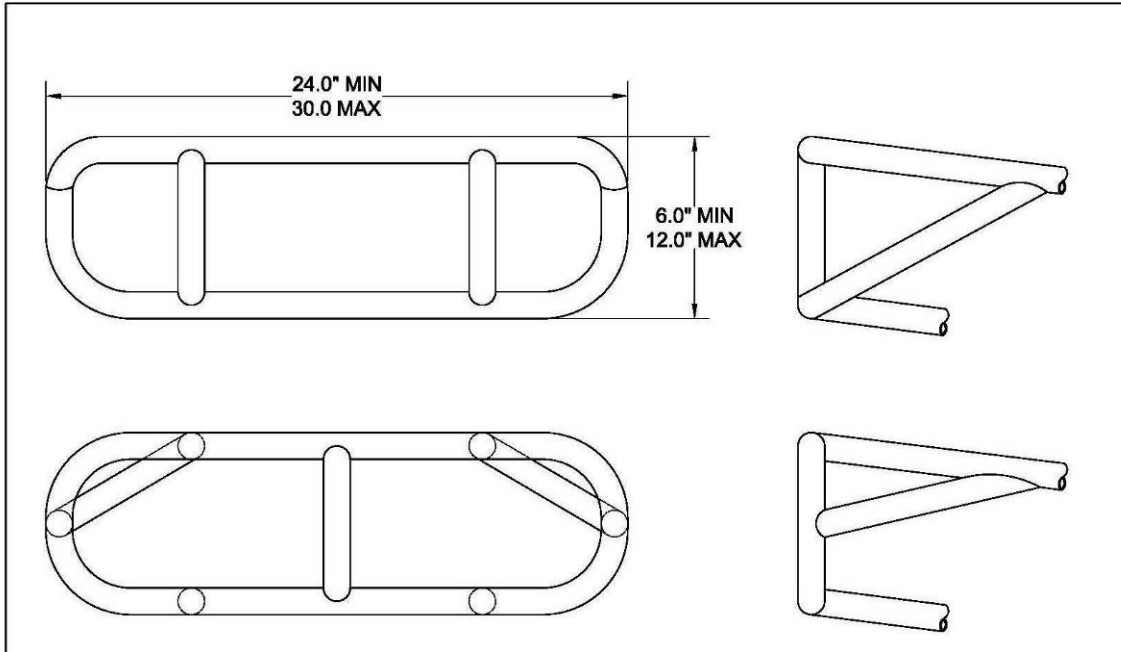

Front Bumper

NOTE:
BUMPERS MUST BE CONSTRUCTED
OF 1 1/4" X 0.095 TUBING AND
MAINTAIN A HEIGHT OF 18"
MEASURED FROM THE GROUND TO
THE MIDDLE OF THE BUMPER

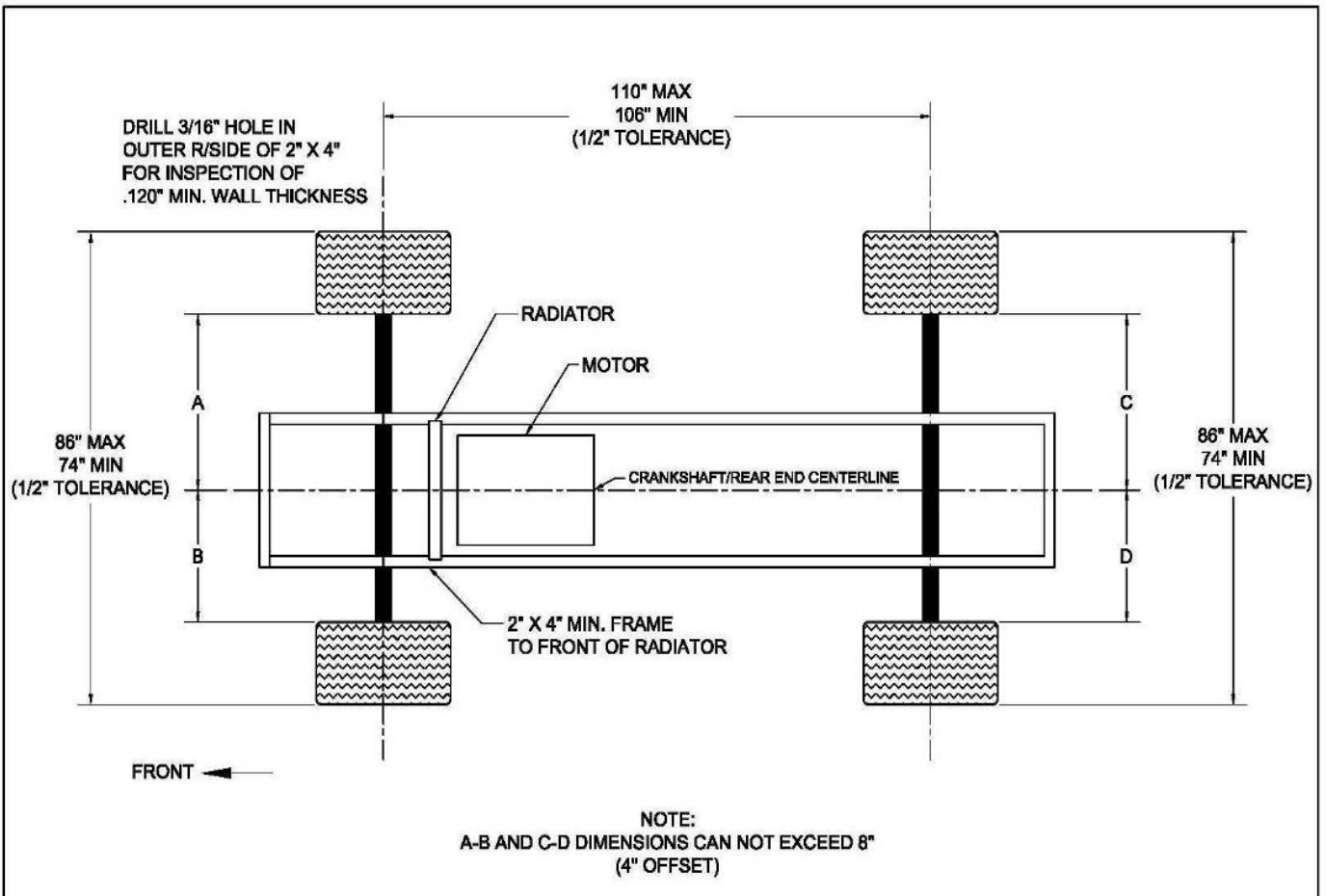

Chassis Diagram

Roof Angle

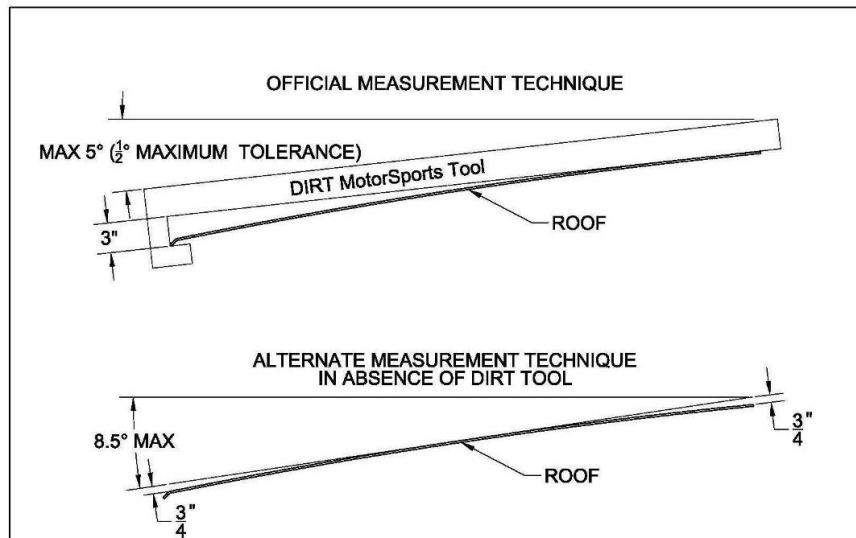

Roof Profile

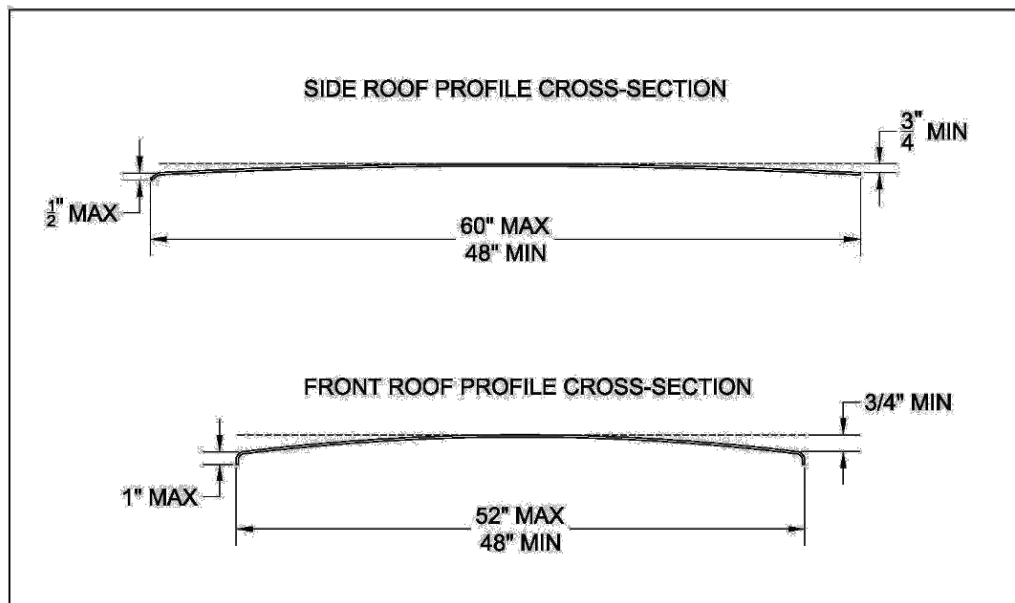

REVISION B:
2/24/05, $1\frac{1}{4}$ " DIMENSION
CHANGED TO $\frac{3}{4}$ ".

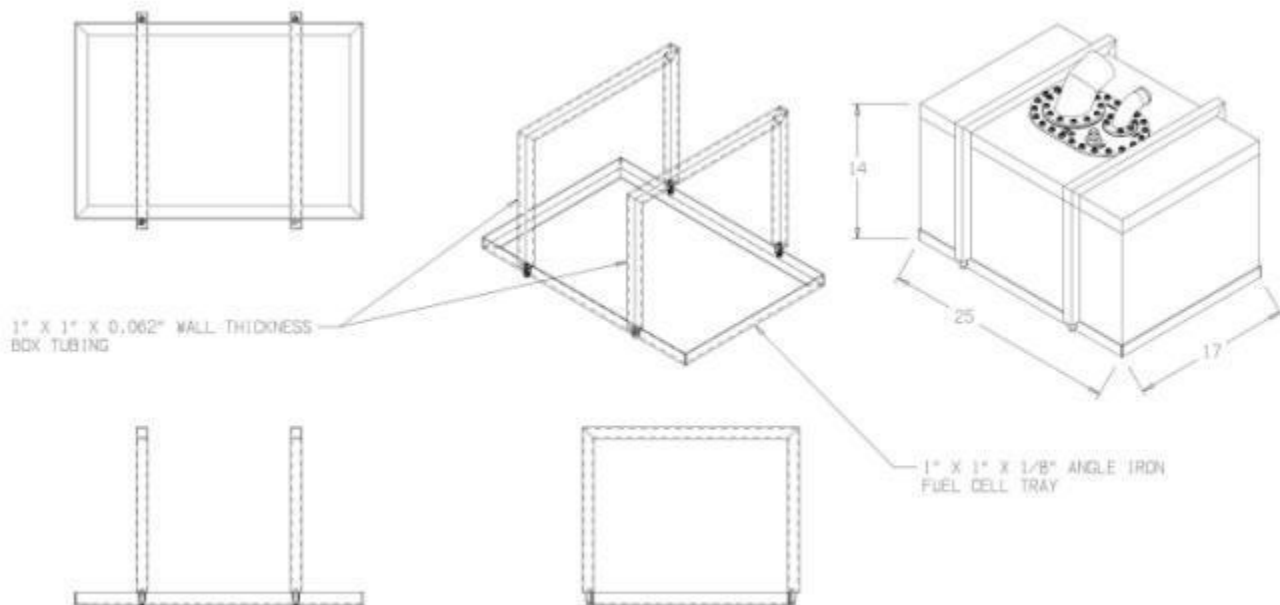

Fuel Cell Straps

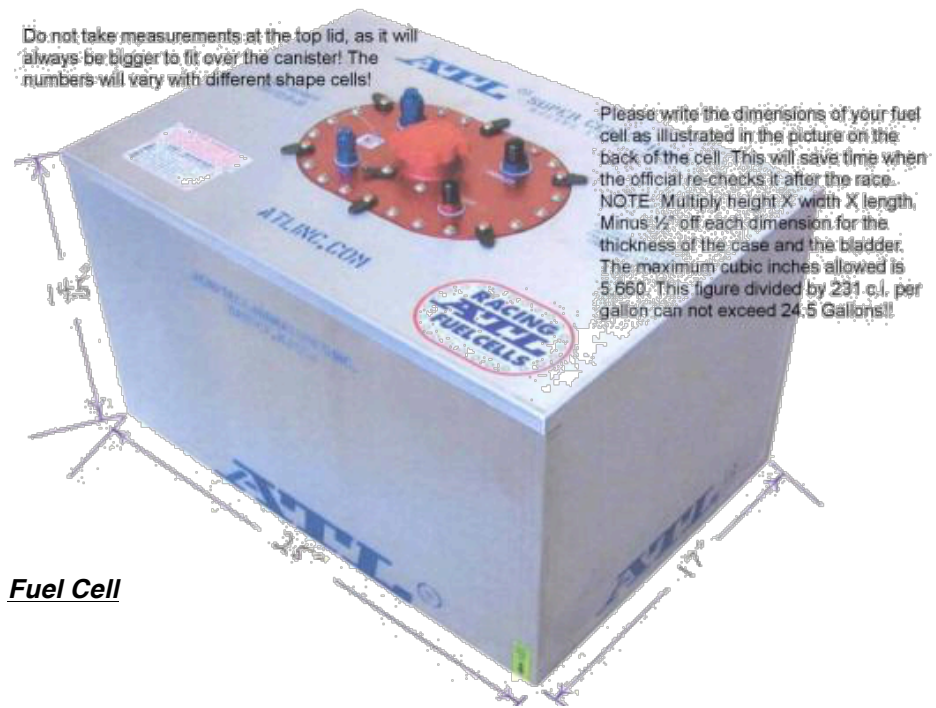

Rub Rail

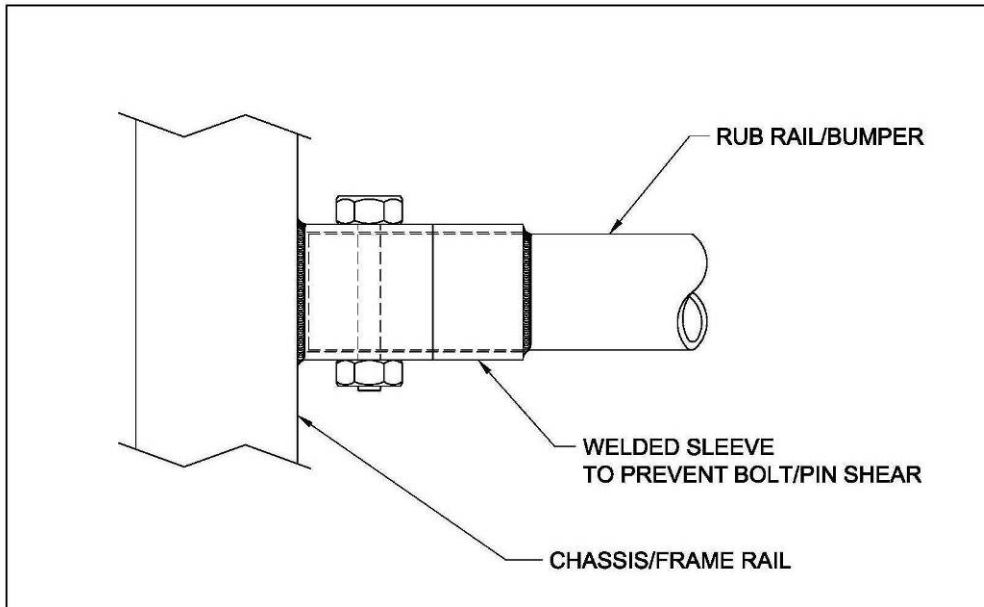

**Pro
Stock**

Transponder Location

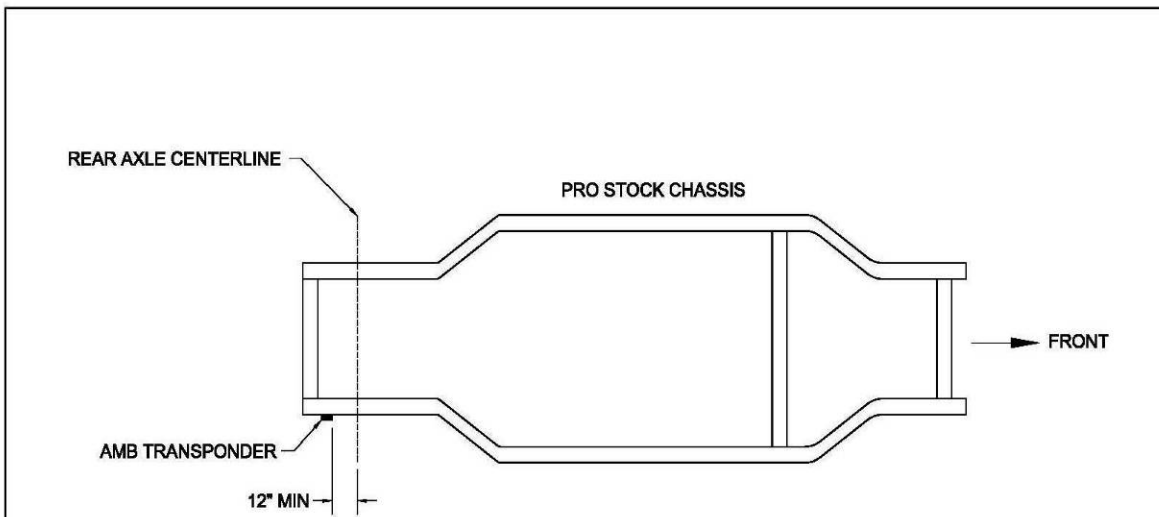

Transponders must be mounted on the right rear frame rail a minimum of 12" from the rear axle centerline. The transponder must be mounted vertically with no obstruction between the transponder and the ground. The transponder may not protrude below the lowest chassis rail. It is recommended that a shield be installed in front of the transponder for protection from clay and debris. The shield can not be made of metal or carbon fiber. If using a rechargeable transponder with a mounting bracket, it is recommended that additional support like a tie wrap or similar be used. Do not rely solely on the cotter pin.